



Istituto Nazionale di Fisica Nucleare



Dark Photon search with PADME at LNF

Gabriele Piperno for the PADME collaboration

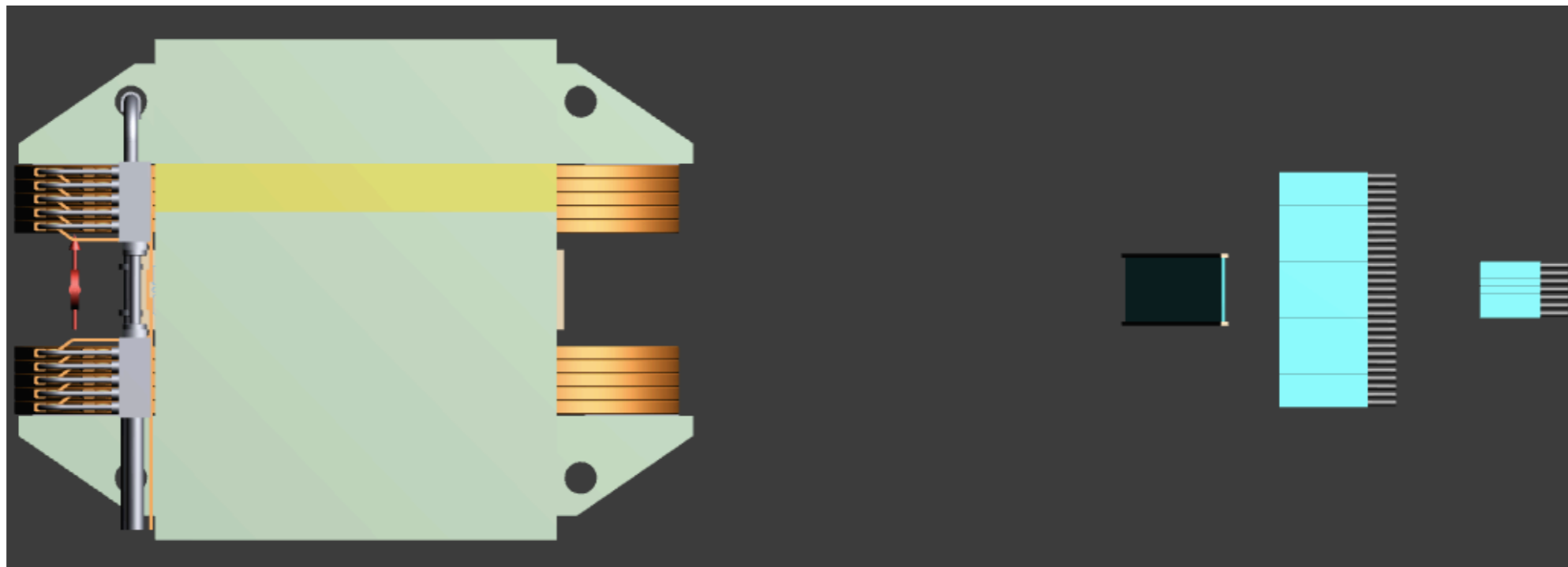

The Dark Matter problem

Evidences:

- spiral galaxies
- Cosmic Microwave Background
- gravitational lensing
- galaxy clusters
- Big Bang Nucleosynthesis
- large scale structures

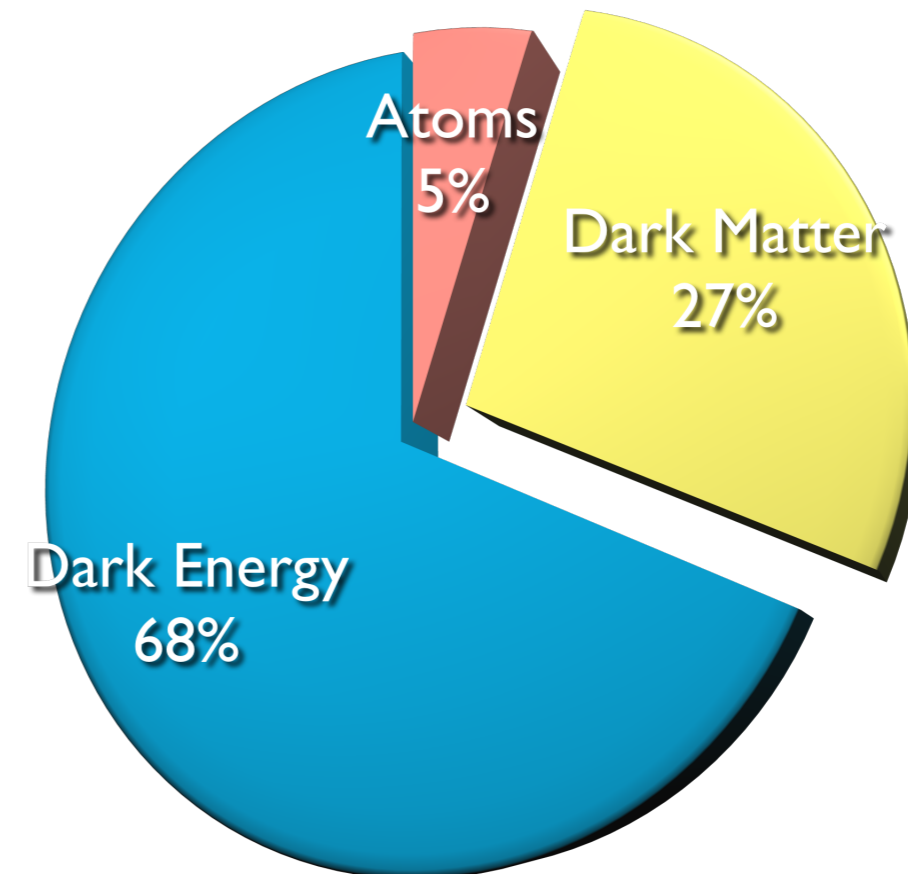

Properties:

- stable (half life \sim universe age)
- cold (non relativistic)
- gravitational force
- non baryonic

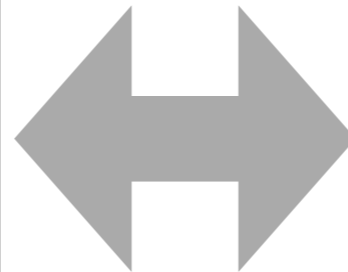

Open questions:

- DM nature
- interaction(s) w/ SM
- A whole new dark sector?
- dark sector forces?

Dark Photon

Possible solution to the DM elusiveness:
DM does not interact directly w/ SM, but by means of “portals”.

The simplest model adds a U(1) gauge symmetry and its boson: the Dark Photon A'

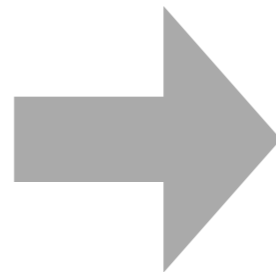

- SM particles are neutral under this symmetry
- new field couples to the SM w/ effective charge ϵq

Dark Sector

Portals (A')

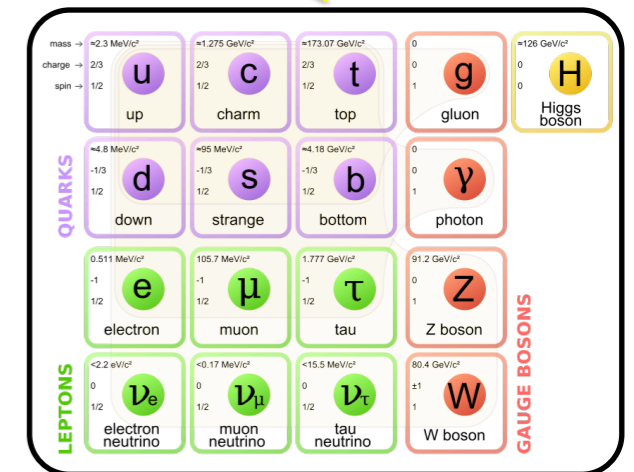

Additionally the A' could (partially) explain the $(g-2)_\mu$ discrepancy

A' characteristics in the simplest model above:

- $1 \text{ MeV} < m_{A'} < 1 \text{ GeV}$
- $\epsilon \gtrsim 10^{-3}$

Purely indicative numbers: it has been recently discarded as a solution

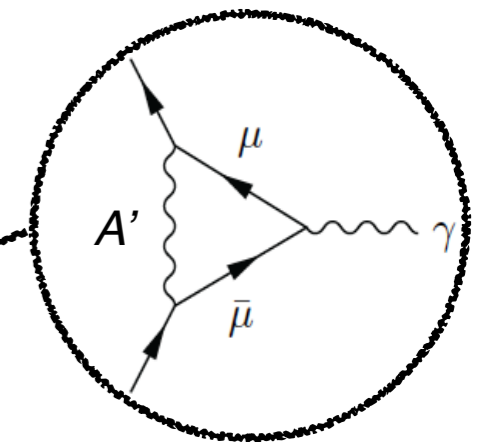
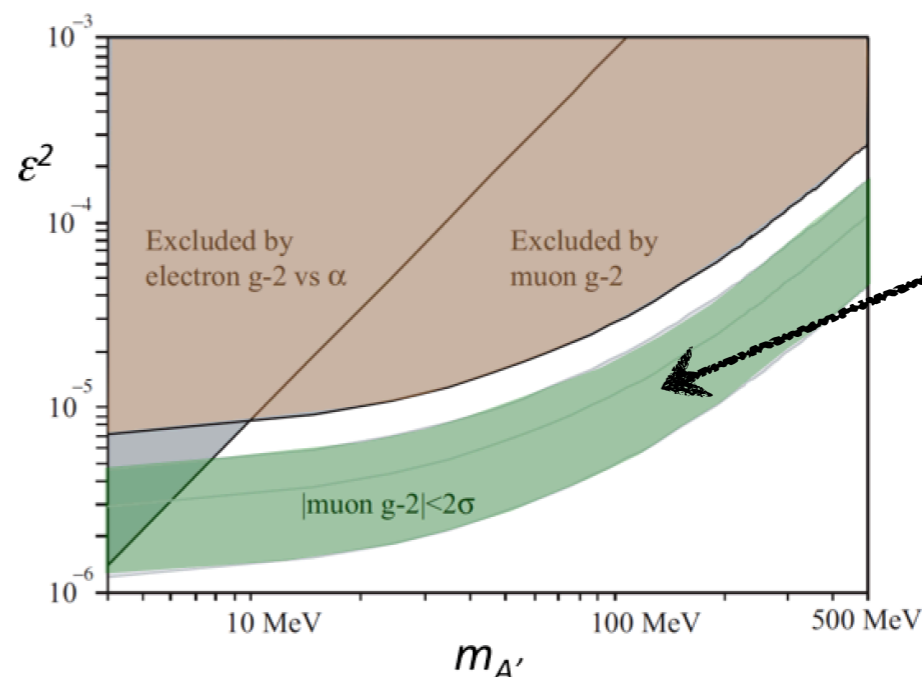

Dark Photon production

In e^+/e^- collisions Dark Photon can be produced in 3 main ways:

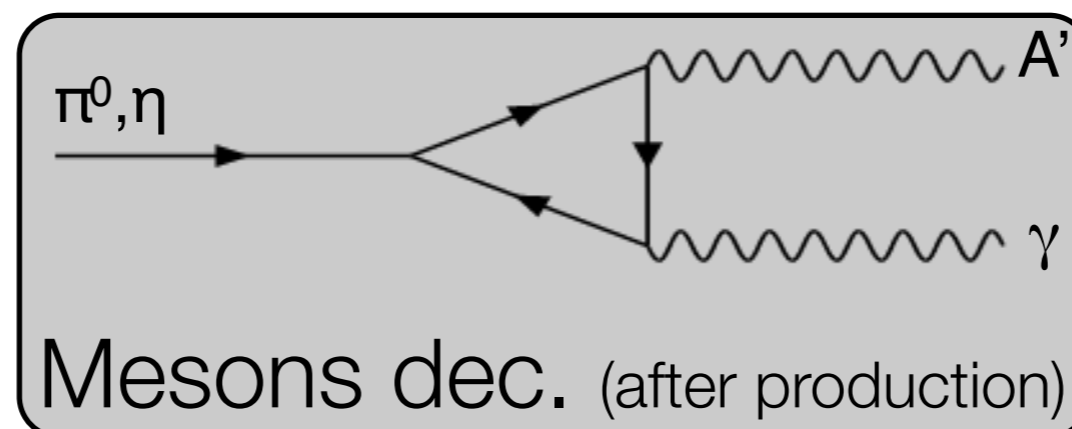
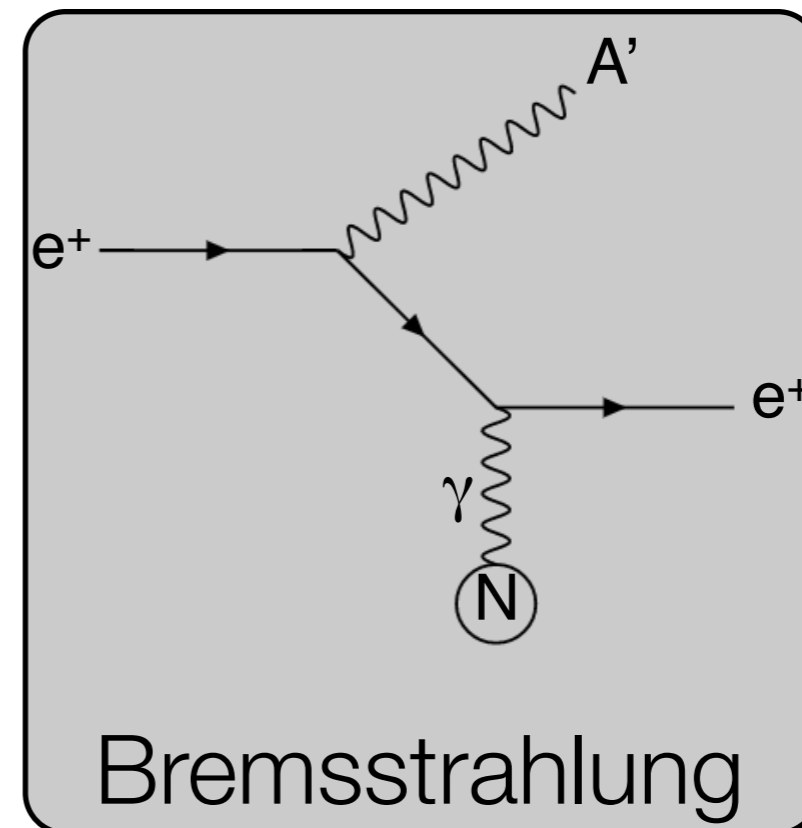
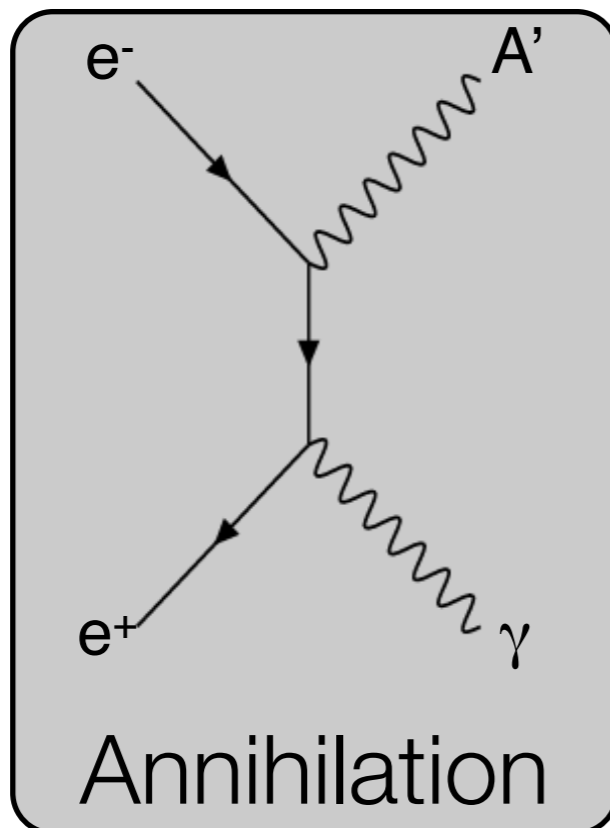

Dark Photon decay

Visible decays

If DM particles w/ $m_{\text{DM}} < m_{A'}/2$ do not exist:

- $A' \rightarrow \text{SM}$ (visible) decays
 - up to $2m_{\mu}$, $\text{BR}(e^+e^-) = 1$ (if $m_{A'} > 2m_e$)

A' lifetime proportional to:
 $1/(\alpha \varepsilon^2 m_{A'})$

Invisible decays

If DM particles w/ $m_{\text{DM}} < m_{A'}/2$ exist:

- $A' \rightarrow \text{DM}$ (invisible) decays w/ (likely) $\text{BR} \approx 1$
- SM decays suppressed by a factor ε^2

A' lifetime proportional to:

$$1/(\alpha_{\text{D}} m_{A'})$$

α_{D} : A' coupling constant to the Dark Sector

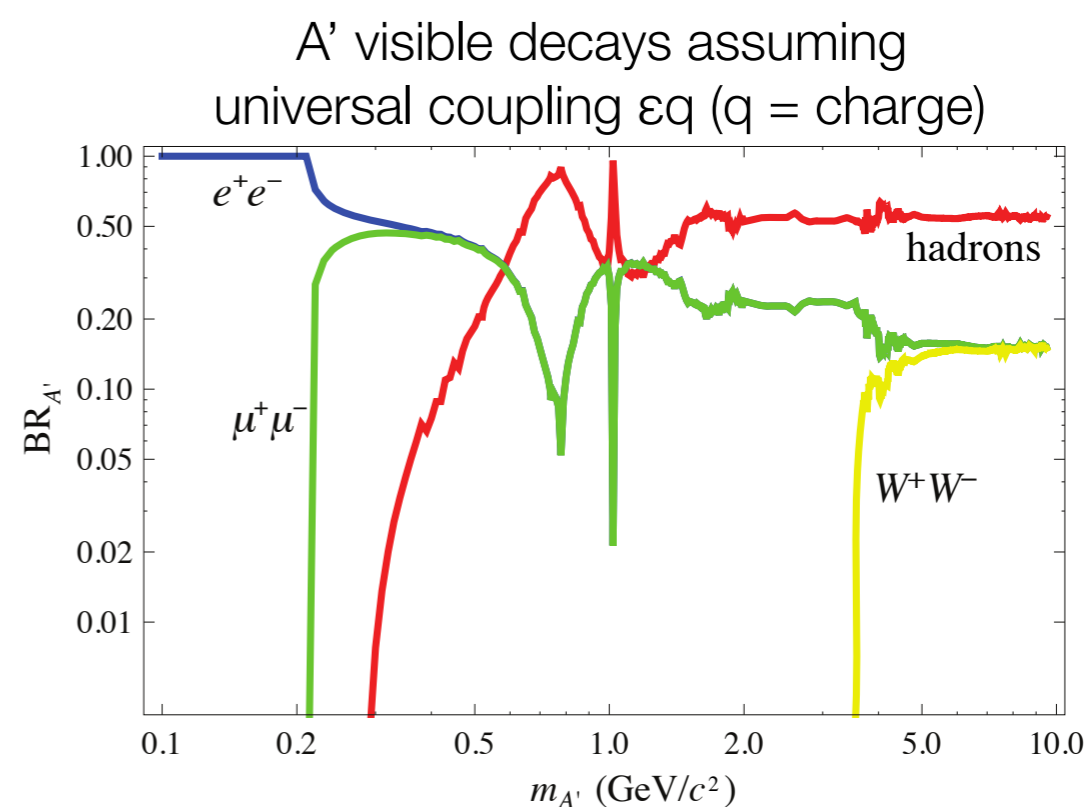

Visible search status

Techniques:

- beam dump (bremsstrahlung)
 - A' decay products detection after high z target (A' production) + shield (SM absorption)

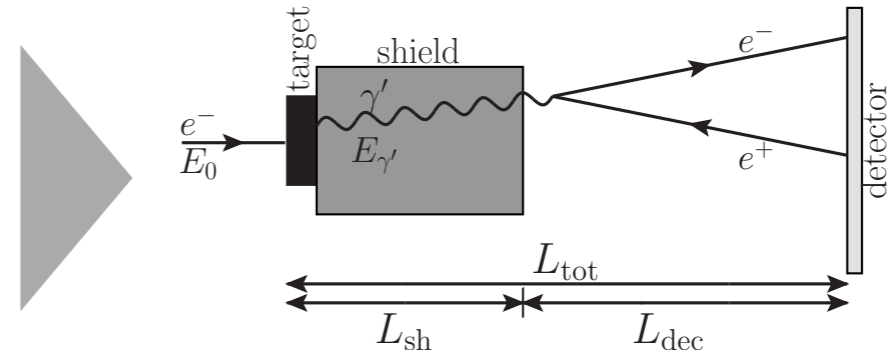

- fixed target (bremsstrahlung, annihilation)
 - bump hunt in invariant mass spectrum, displaced vertices

- meson decay
 - only if A' couples w/ quarks
 - old experiments reanalysis

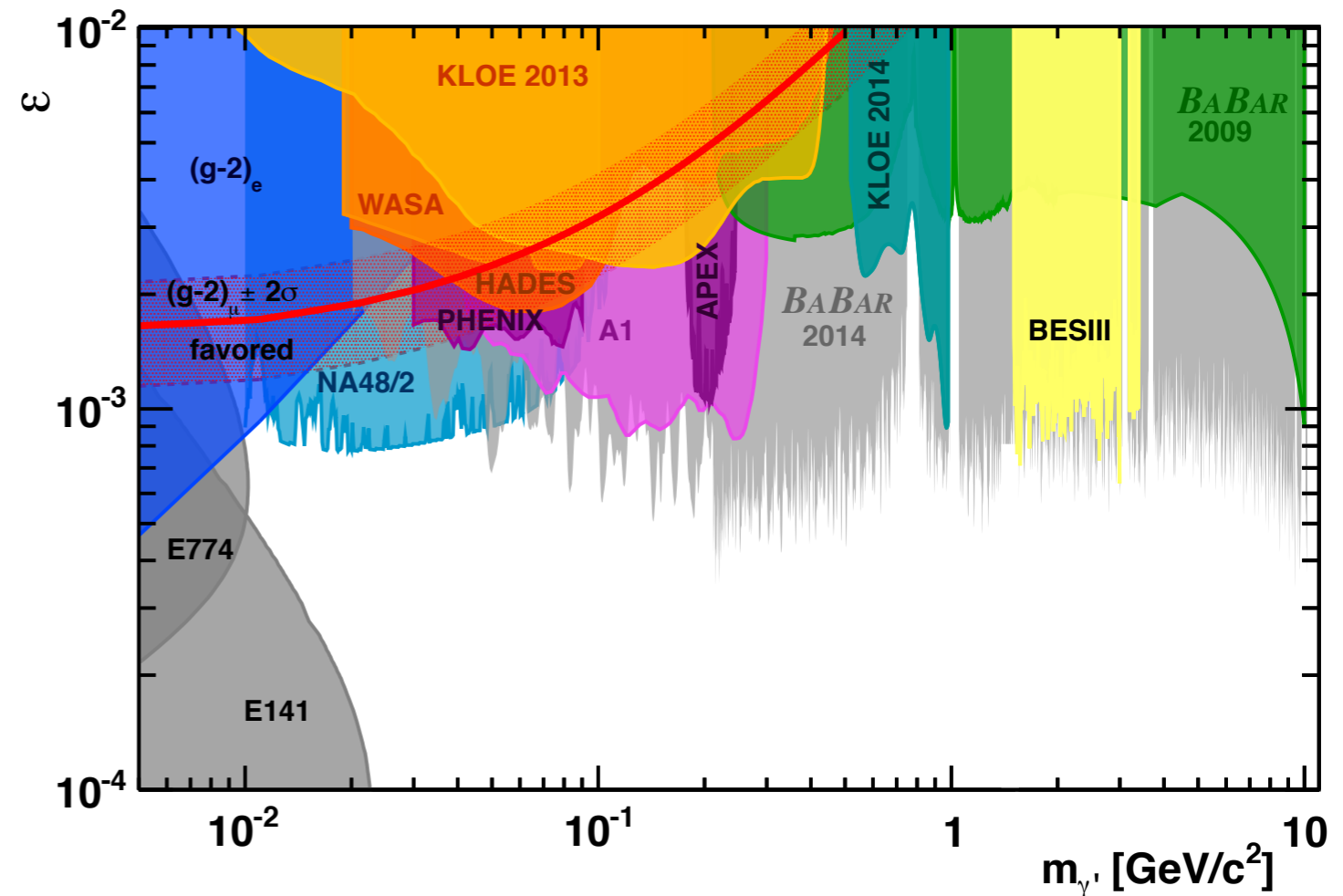

$(g-2)_\mu$ excluded in the simplest model, but still a lot of interest

Invisible search status

Techniques:

- DM scattering (bremsstrahlung)
 - detect by scattering the produced DM
 - needed 4 parameters ($\epsilon, m_{A'}, m_{DM}, \alpha_D$)
- missing mass search (annihilation)
 - kinematically constrained process
 - no assumption on A' decay chain

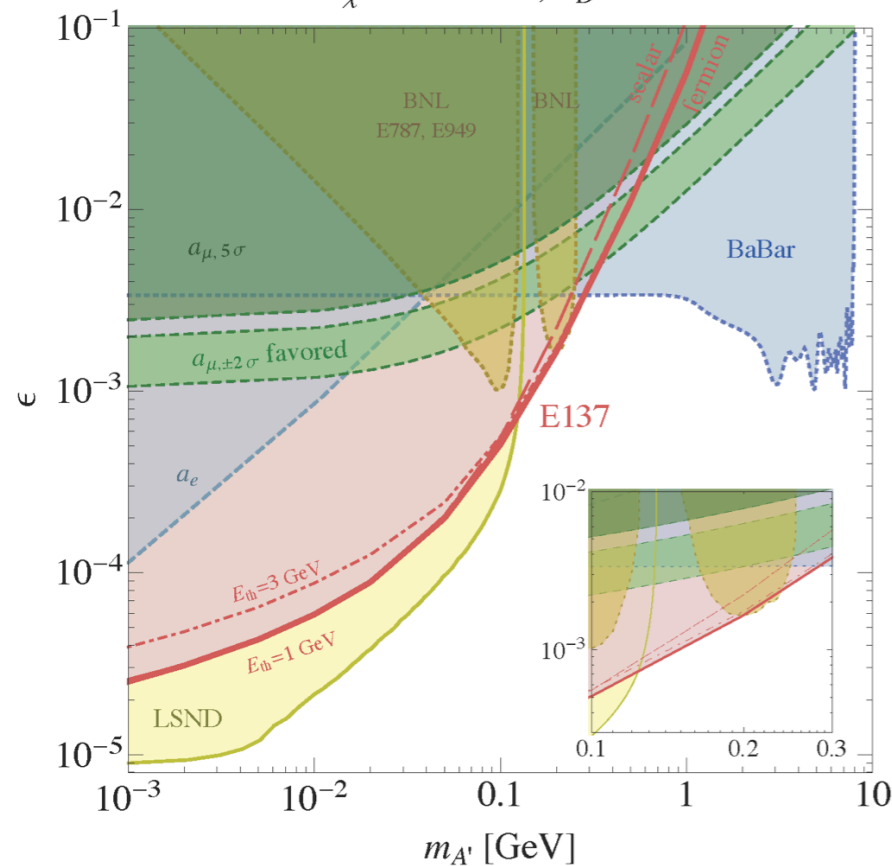
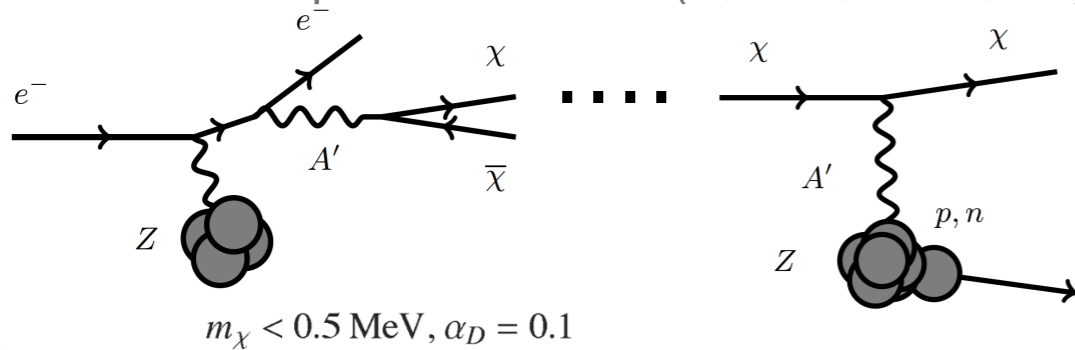

← Not directly comparable →

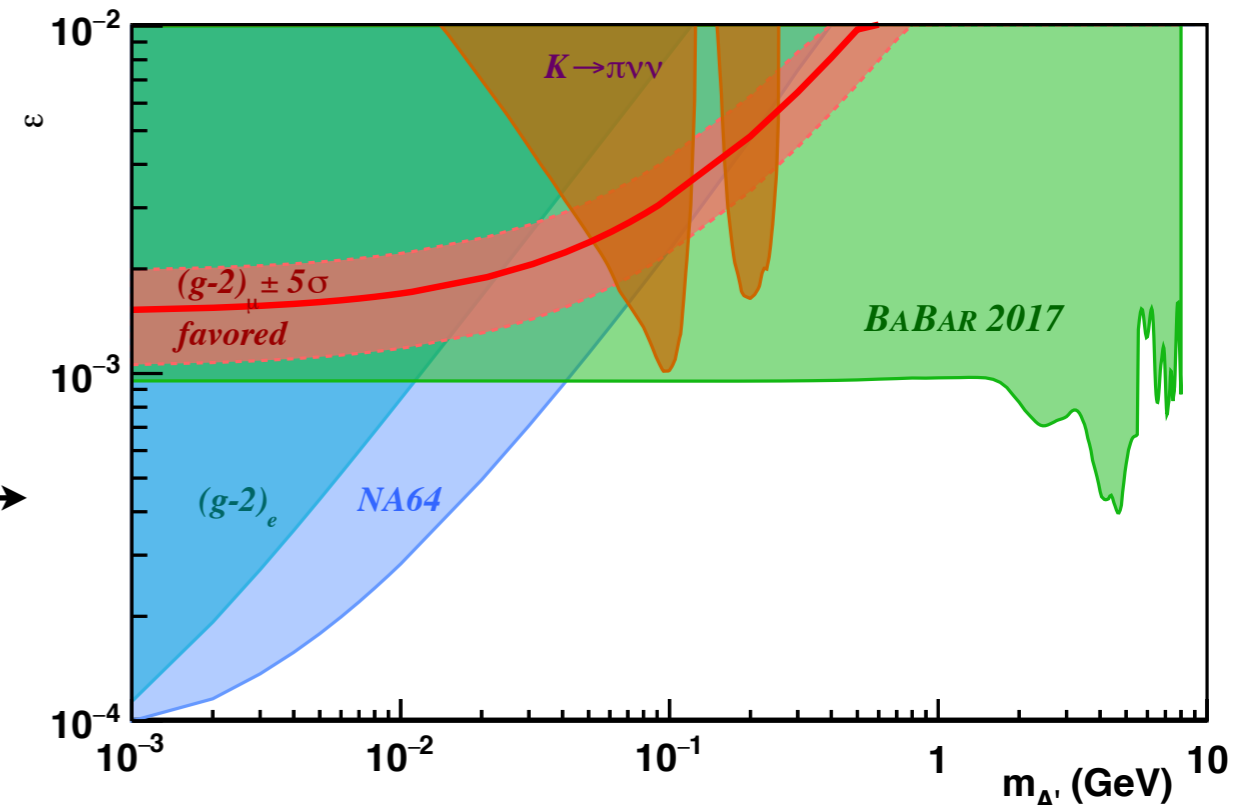

The PADME approach

A' search in e^+e^- annihilations looking for missing mass (invisible decay) in a kinematically constrained condition

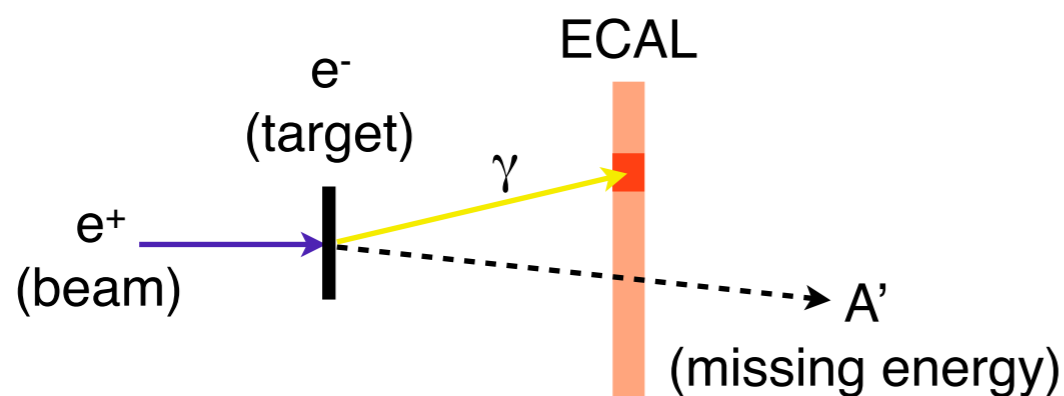

M_{Miss}^2 for different $M_{A'}$

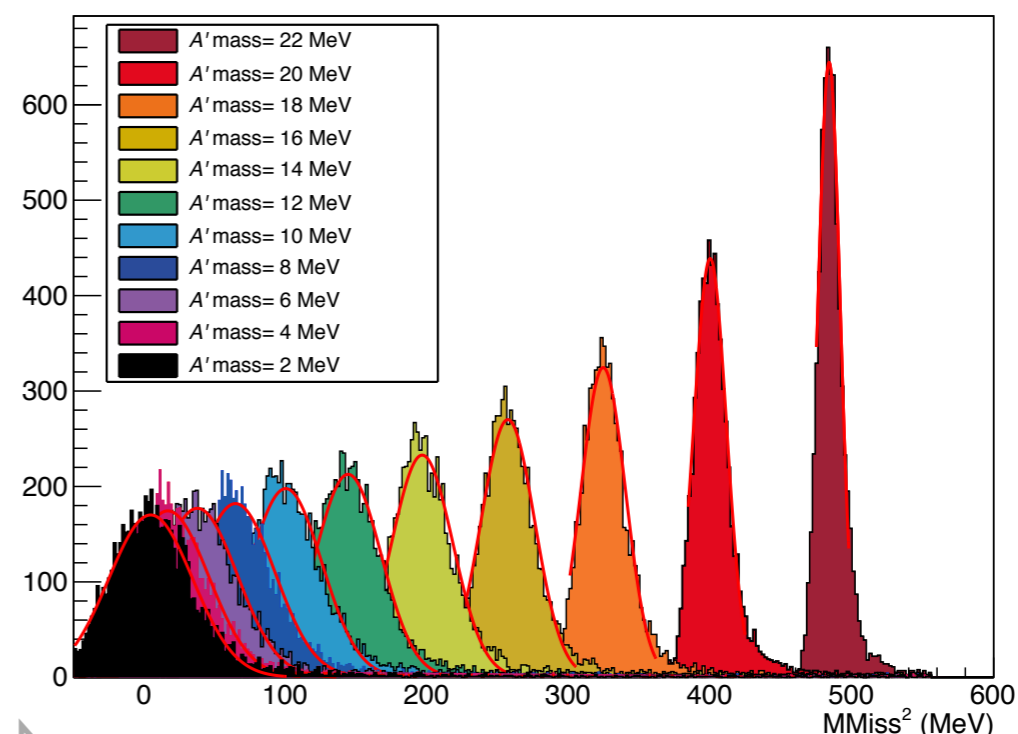

- known beam energy and position
- measured photon energy and position

$$m_{\text{Miss}}^2 = (\mathbf{P}_{\text{beam}} + \mathbf{P}_e - \mathbf{P}_\gamma)^2$$

- minimal model dependent assumptions: A' couples to leptons
- coupling of any new light particle produced in e^+e^- annihilation can be limited: **Dark Photon, Axion Like Particles, Dark Higgs**

The detector

active target

- diamond (low z)
- 100 μm thickness
- info on beam time, spot size, e^+ number

(high energy) e^+/e^- veto

- plastic scintillator bars

small angle calorimeter

- 25 PbF_2
- $3 \times 3 \times 15 \text{ cm}^3$
- 0-20 mrad ang. cov.

electromagnetic calorimeter

- 616 $2.1 \times 2.1 \times 23 \text{ cm}^3$ BGO
- cylindrical shape w/ central hole
- 20-95 mrad ang. cov.
- $(1-2)\%/\sqrt{E}$

e^+ beam

- 550 MeV
- 5000 e^+ per bunch
- 40 ns bunch, every 20 ms

MBP-S dipole (upper part not shown)

- 0.5 T
- 1 m length. \times 23 cm gap

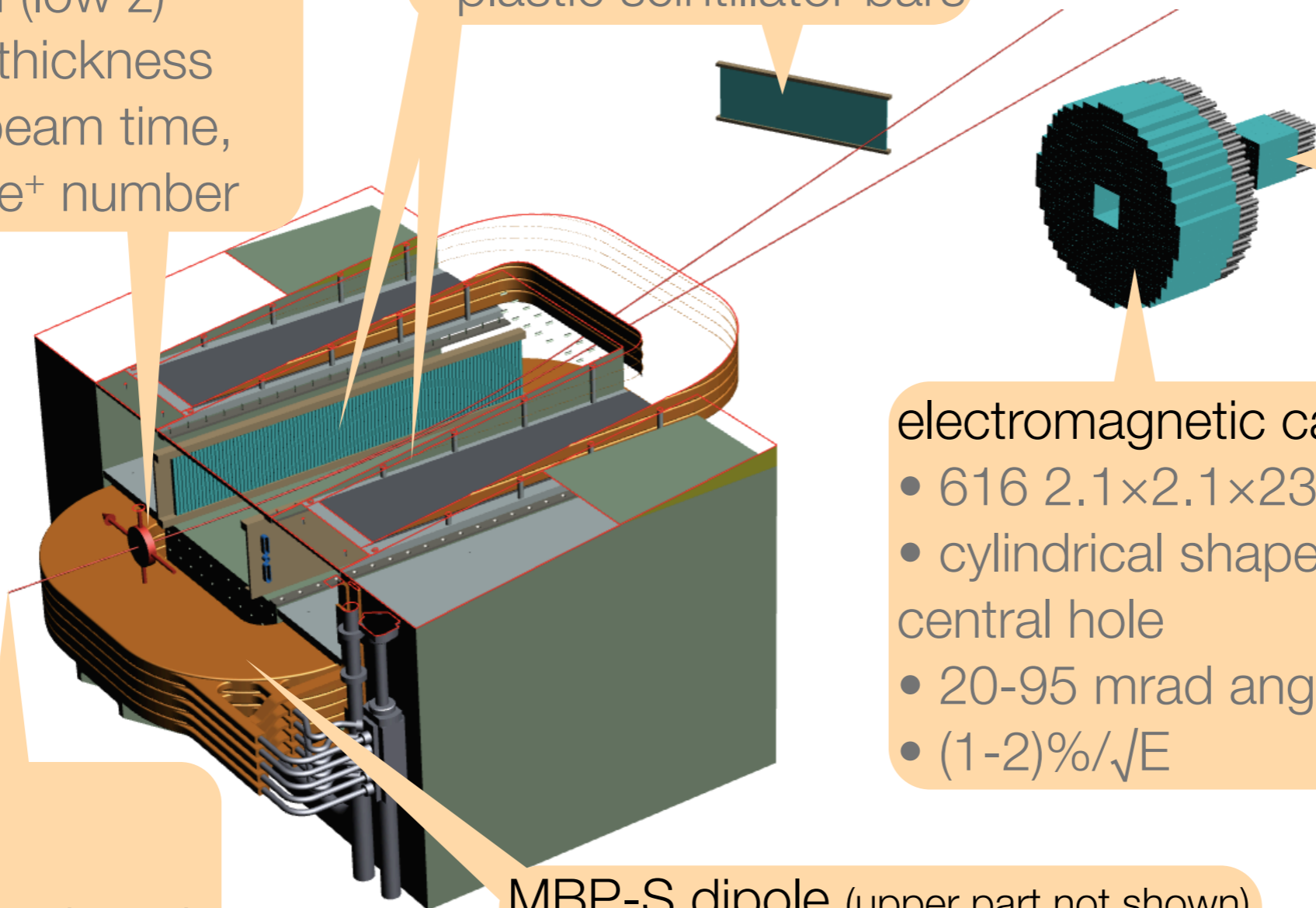

Detector top view (w/ signal)

Signal:

- single γ in the calorimeter
- nothing in the other detector components

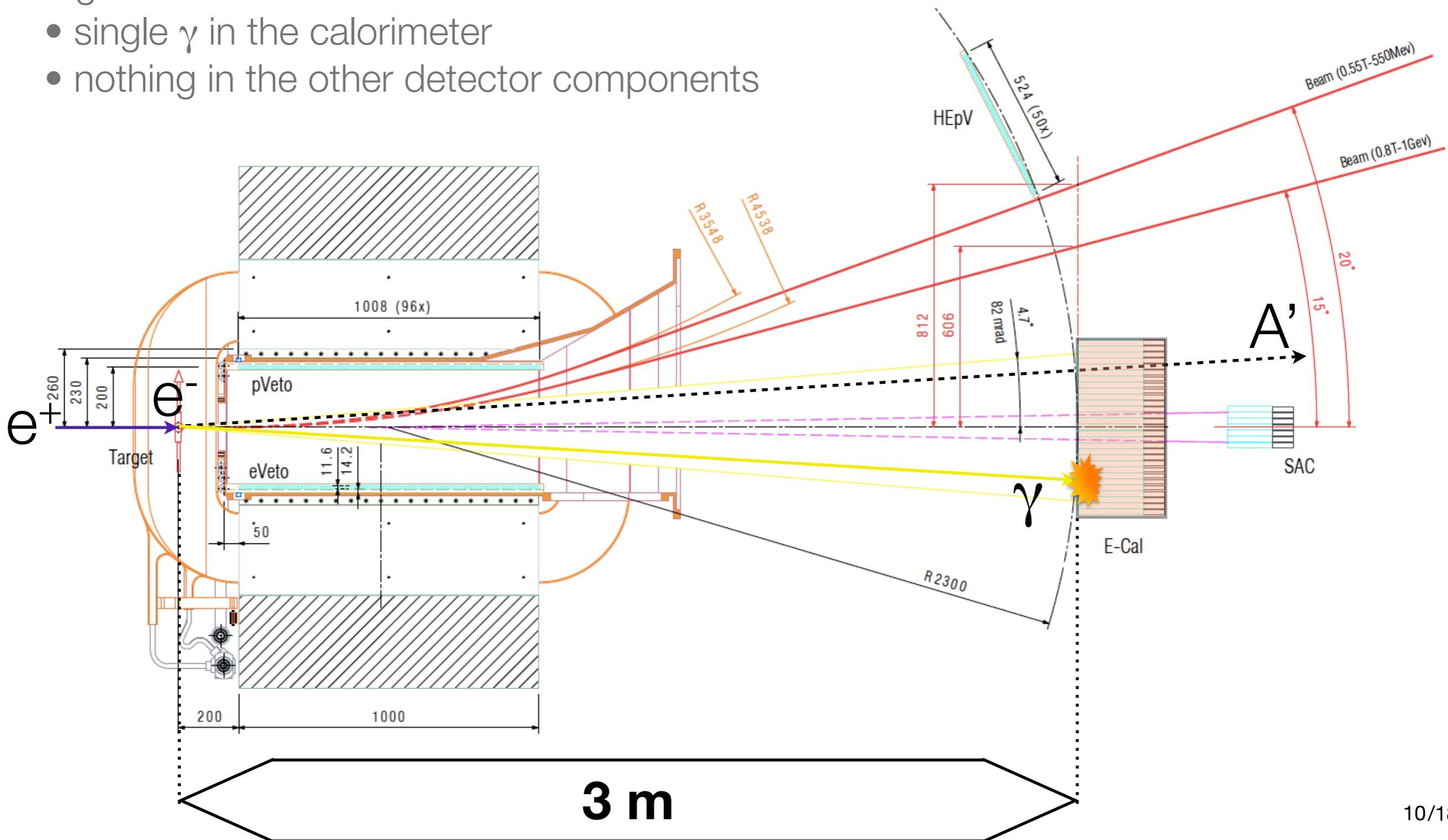

Active target

Features:

- Diamond (low z, reduced brems.)
- Dim.: $20 \times 20 \times 0.1 \text{ mm}^3$
- 16 horiz. \times 16 vert. active graphitic strips (average informations on beam)
- σ_{x-y} (beam position) $< 2 \text{ mm}$
- in vacuum w/ movement system

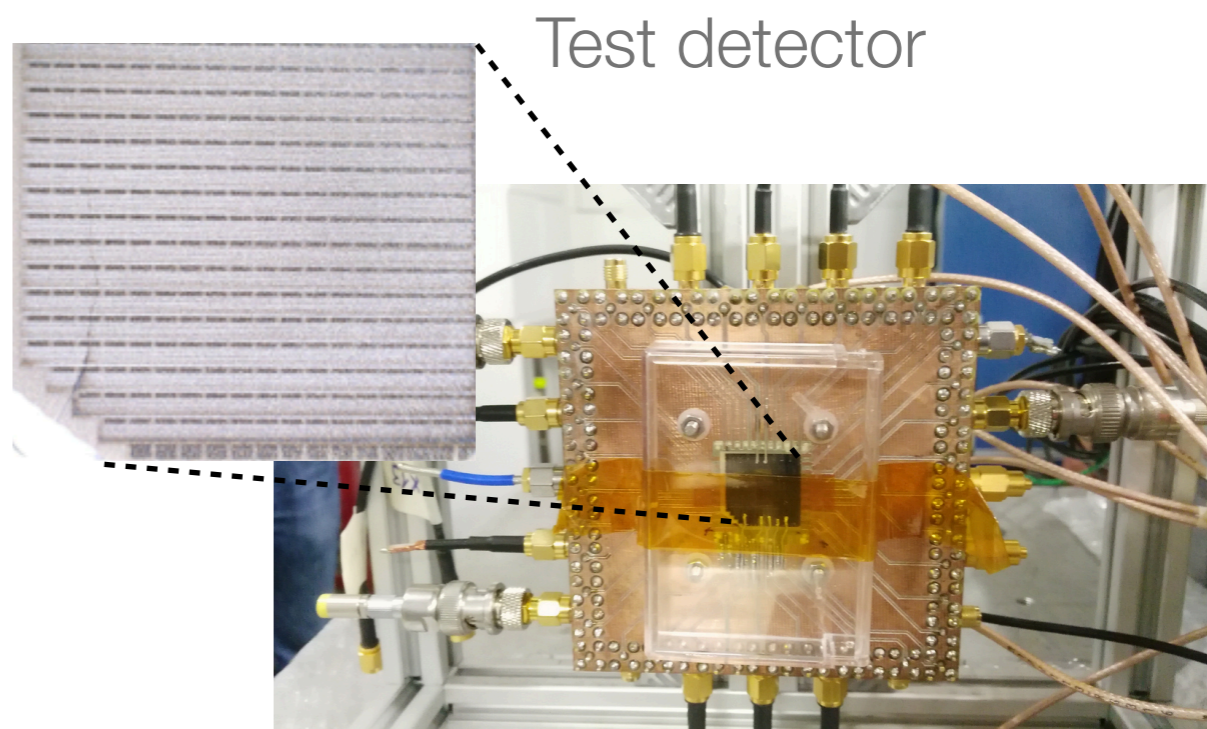

Test detector results

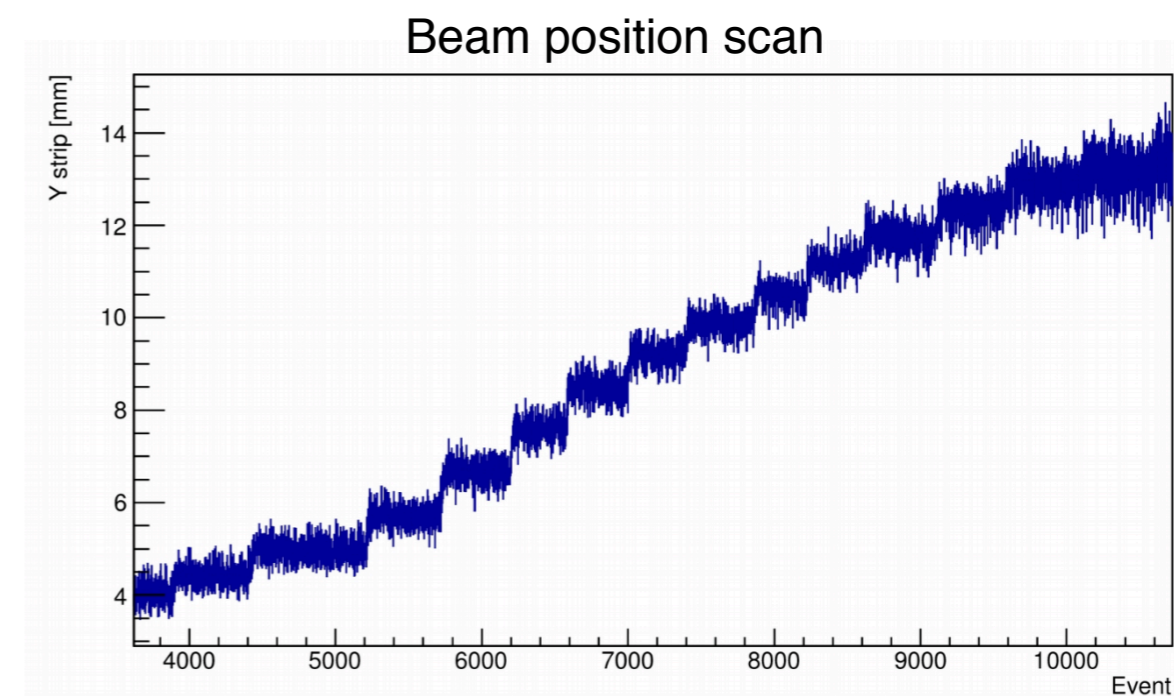
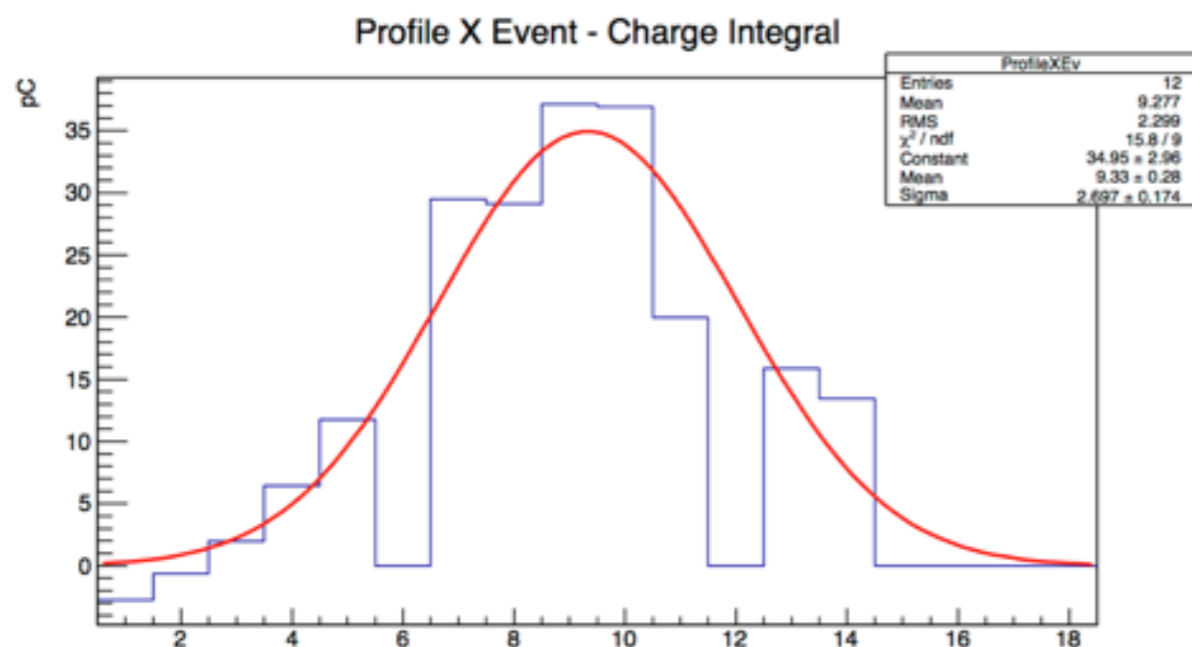

Electromagnetic calorimeter (1)

Features:

- $\sigma_E \approx (1-2)\%/\sqrt{E}$
 - high γ statistic
 - containment
- cluster time resolution < 1 ns
- angular resolution ≈ 1 mrad
- angular coverage: [20,93] mrad
- angular acceptance: [26,83] mrad
- central hole for brems. to SAC (faster)

Parameter:	ρ	MP	X_0^*	R_M^*	dE^*/dx	λ_I^*	τ_{decay}	λ_{max}	n^{\ddagger}	Relative output [†]	Hygro-scopic?	$d(\text{LY})/dT$
Units:	g/cm ³	°C	cm	cm	MeV/cm	cm	ns	nm				%/°C [‡]
NaI(Tl)	3.67	651	2.59	4.13	4.8	42.9	245	410	1.85	100	yes	-0.2
BGO	7.13	1050	1.12	2.23	9.0	22.8	300	480	2.15	21	no	-0.9
BaF ₂	4.89	1280	2.03	3.10	6.5	30.7	650 ^s	300 ^s	1.50	36 ^s	no	-1.9 ^s
							0.9 ^f	220 ^f		4.1 ^f		0.1 ^f
CsI(Tl)	4.51	621	1.86	3.57	5.6	39.3	1220	550	1.79	165	slight	0.4
CsI(pure)	4.51	621	1.86	3.57	5.6	39.3	30 ^s	420 ^s	1.95	3.6 ^s	slight	-1.4
							6 ^f	310 ^f		1.1 ^f		
PbWO ₄	8.3	1123	0.89	2.00	10.1	20.7	30 ^s	425 ^s	2.20	0.3 ^s	no	-2.5
							10 ^f	420 ^f		0.077 ^f		
LSO(Ce)	7.40	2050	1.14	2.07	9.6	20.9	40	402	1.82	85	no	-0.2
LaBr ₃ (Ce)	5.29	788	1.88	2.85	6.9	30.4	20	356	1.9	130	yes	0.2

616 BGO 2.1×2.1×23 cm³
@ 3 m from the target

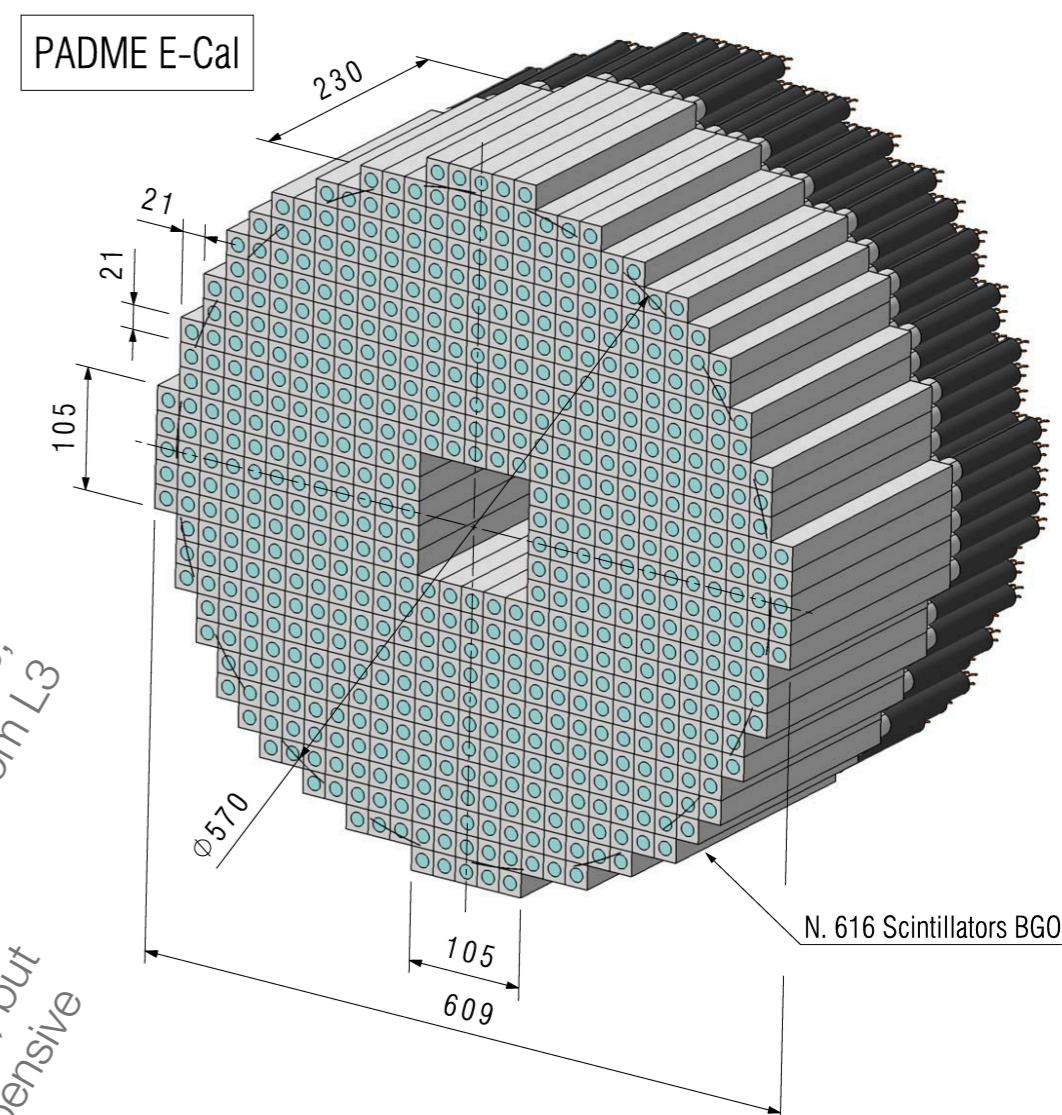

2° best choice,
for free from L3
best choice, but
very expensive

Electromagnetic calorimeter (2)

Dipole gap limits the angular acceptance

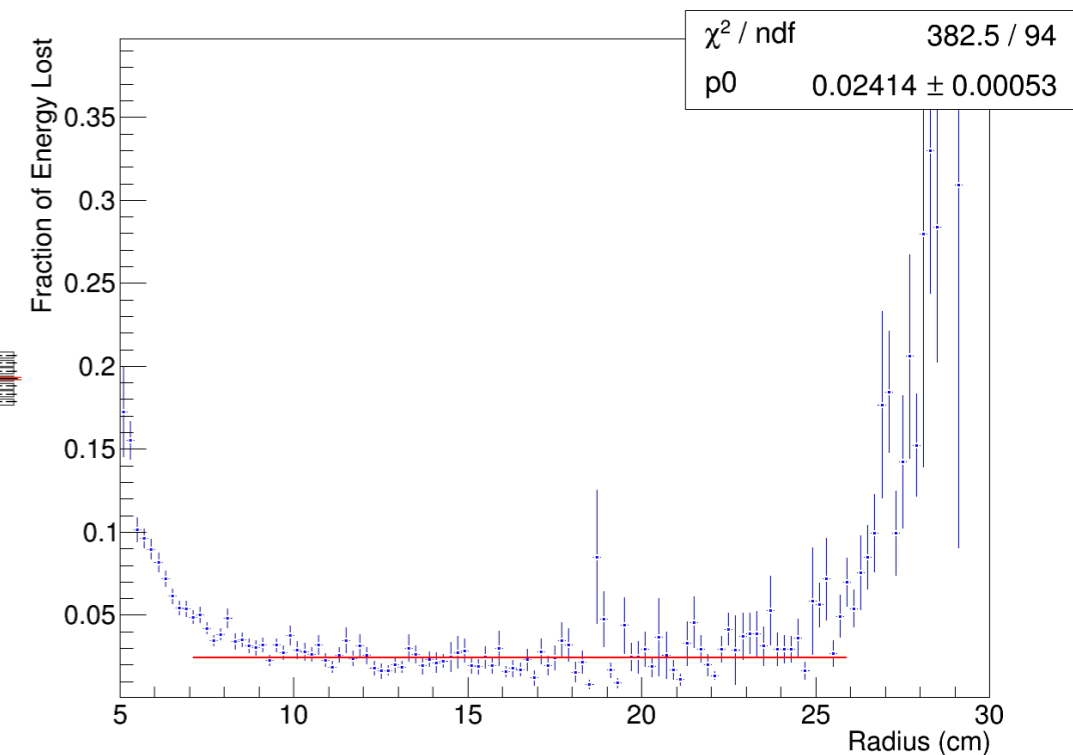
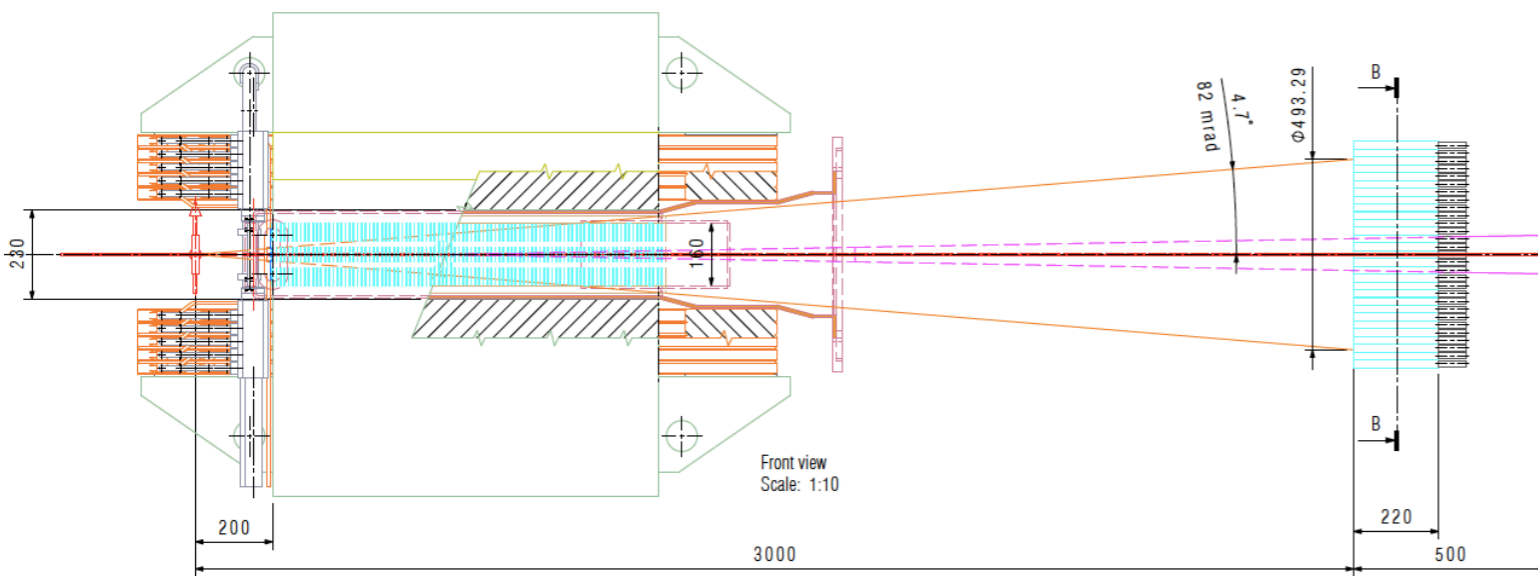

Results w/ a 5x5
BGO (2x2x22
cm³) matrix test

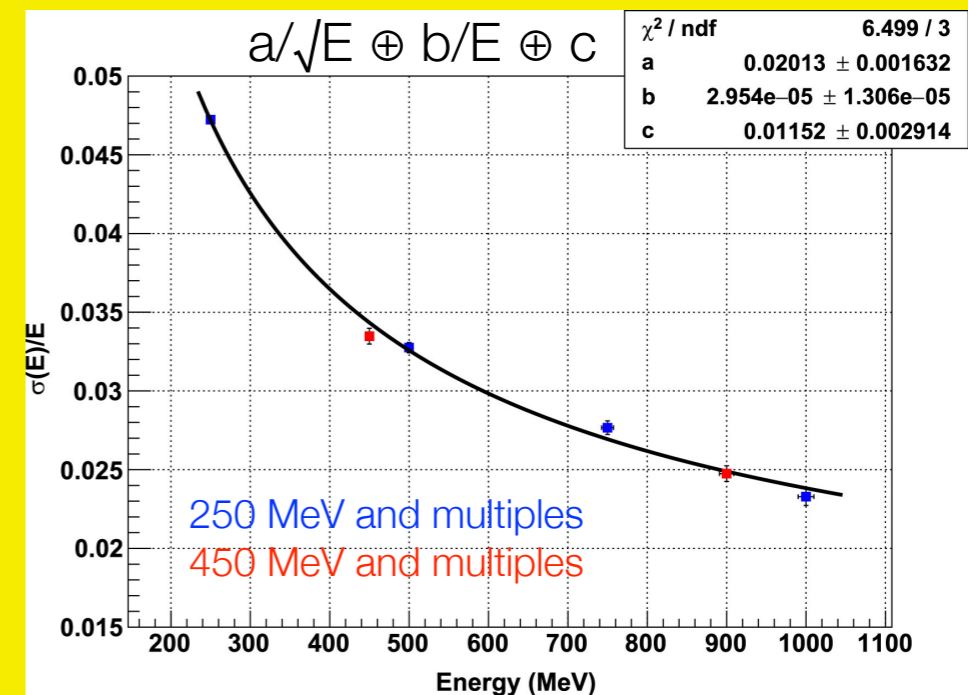

M. Raggi et al., NIM 862, 31 (2017)

The LNF Beam Test Facility

PADME will be placed in the Beam Test Facility of the Laboratori Nazionali di Frascati (~Rome, IT)

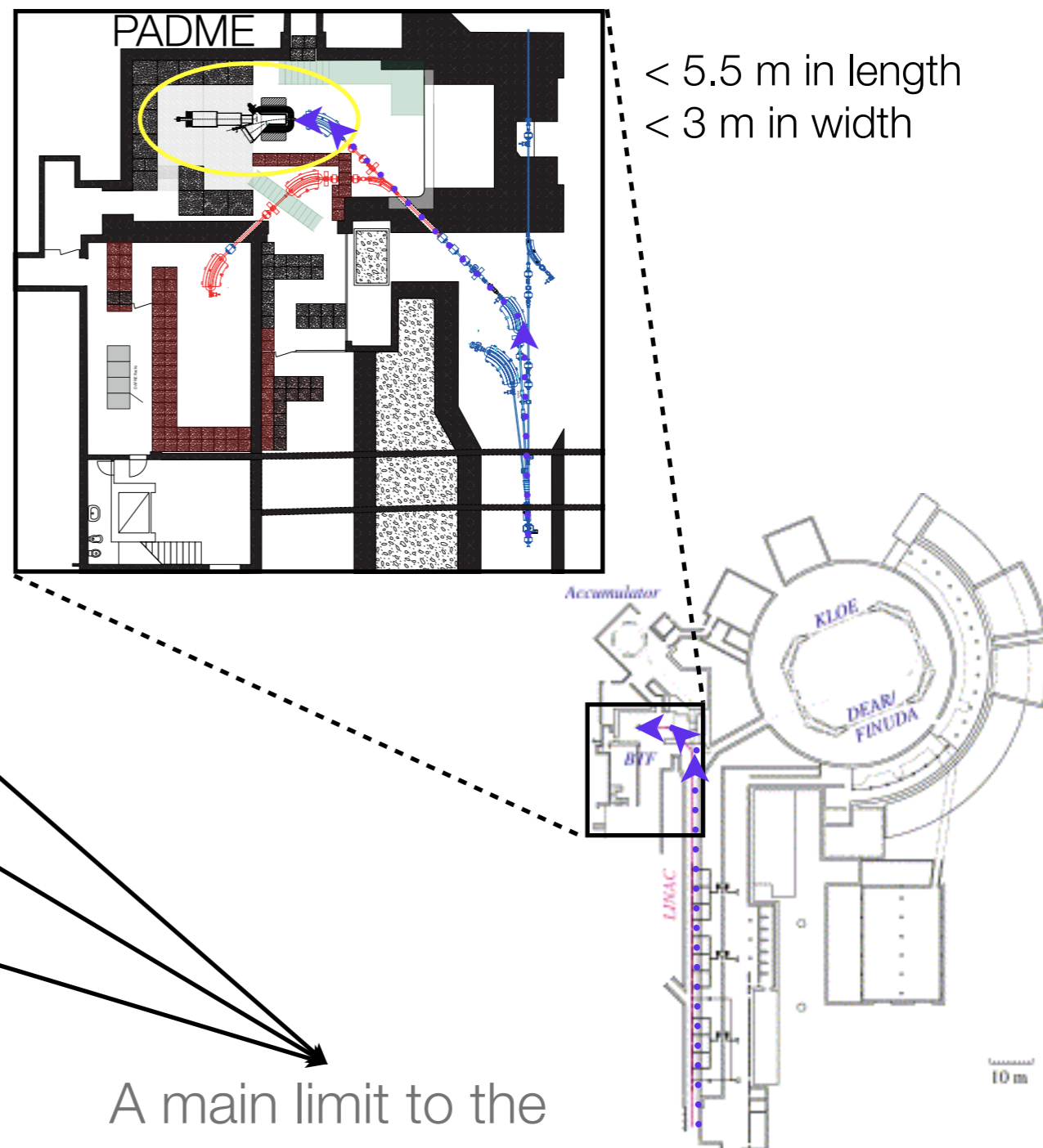

$< 5.5\text{ m}$ in length
 $< 3\text{ m}$ in width

A main limit to the PADME sensitivity arise from the pile-up

	Parasitic mode (DAΦNE working)		Dedicated mode	
	W/ target	W/o target	W/ target	W/o target
Particle species	e^+/e^- selectable by user	e^+/e^- depending on DAΦNE mode	e^+/e^- selectable by user	
Energy [MeV]	25-500	510	25-700 (e^+) 25-700 (e^-)	250-730 (e^+) 250-530 (e^-)
Energy spread	1% @ 500 MeV	1%	1%	
Rep. rate [Hz]	10-49 depending on DAΦNE mode		1-49 selectable by user	
Pulse duration [ns]	10		1.5-40 selectable by user	
Intensity [particles/bunch]	$1-10^5$ depending on energy	$10^7-1.5 \cdot 10^{10}$	$1-10^5$ depending on energy	$10^3-3 \cdot 10^{10}$
Max average flux	$3.125 \cdot 10^{10}$ particles/s			
Spot size [mm]	$0.5-25 (y) \times 0.6-55 (x)$			
Divergence [mrad]	1-1.5			

PADME positron beam

Beam characteristics (referring to a 550 MeV beam on a 100 μm C target):

- Energy spread $\approx 1\%$
- Angular divergence < 1 mrad
- Beam RMS < 1 mm
- Position RMS = 0.25 mm
- Repetition rate = 49 Hz
- Particles per bunch ≈ 5000
(limited by pile-up)
- Pulse duration = 40 ns

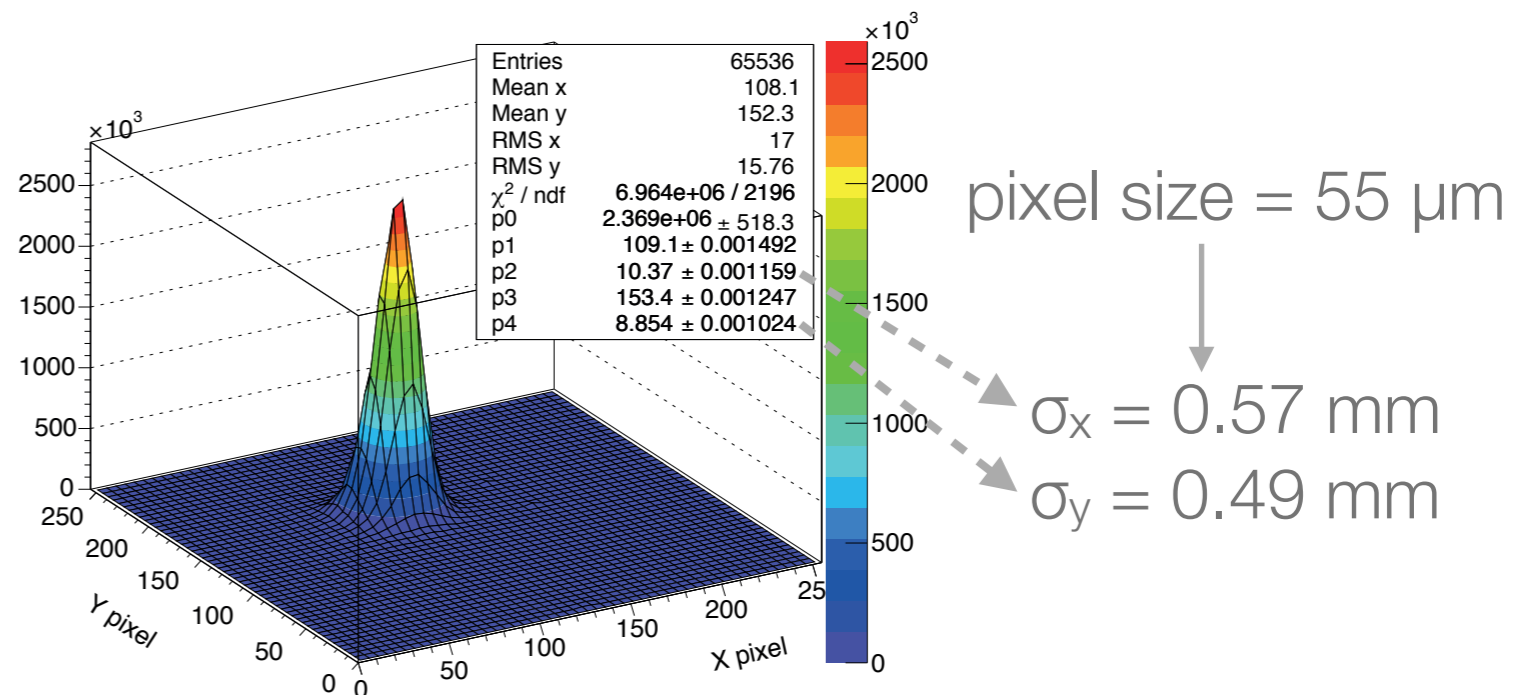

Beam spot example @ 450 MeV

Increasing the pulse duration it is possible to collect more statistics maintaining the same pile-up level

We performed some tests reaching a bunch length up to 280 ns. In principle up to 5 μs length is possible, but requires a (never tried or non-reversible) different linac configuration.

Backgrounds

Largest backgrounds:

- $e^+ e^- \rightarrow \gamma \gamma (\gamma)$
- $e^+ N \rightarrow e^+ N \gamma$
- pile-up

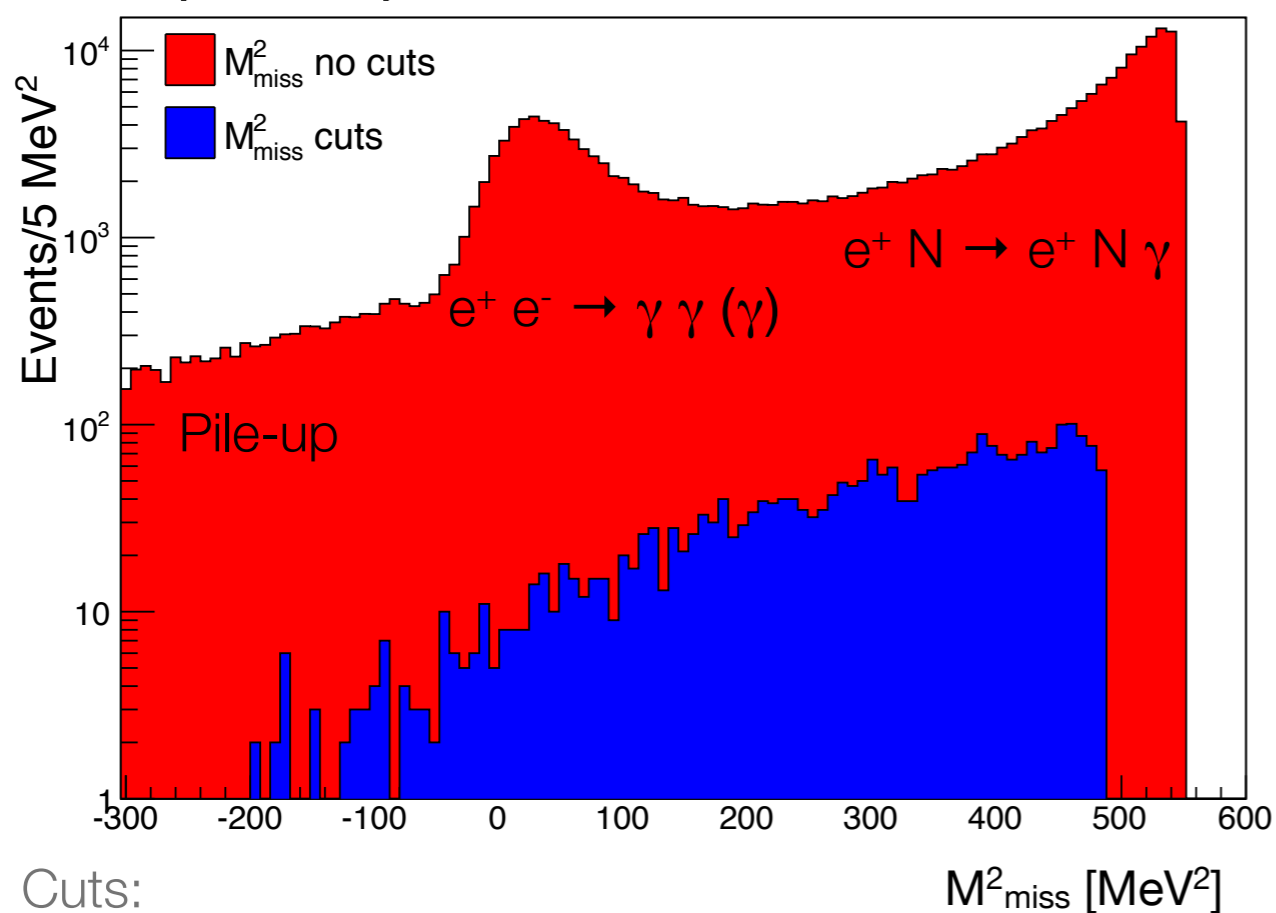

Cuts:

- 1 cluster in ECAL fiducial volume
- no hits in vetoes
- no γ in the SAC w/ $E_\gamma > 50$ MeV
- $20-150 \text{ MeV} < E_\gamma < 120-350 \text{ MeV}$ (depending on $m_{A'}$)

Backgrounds geometry

Annihilation (+ISR): $e^+ e^- \rightarrow \gamma \gamma (\gamma)$

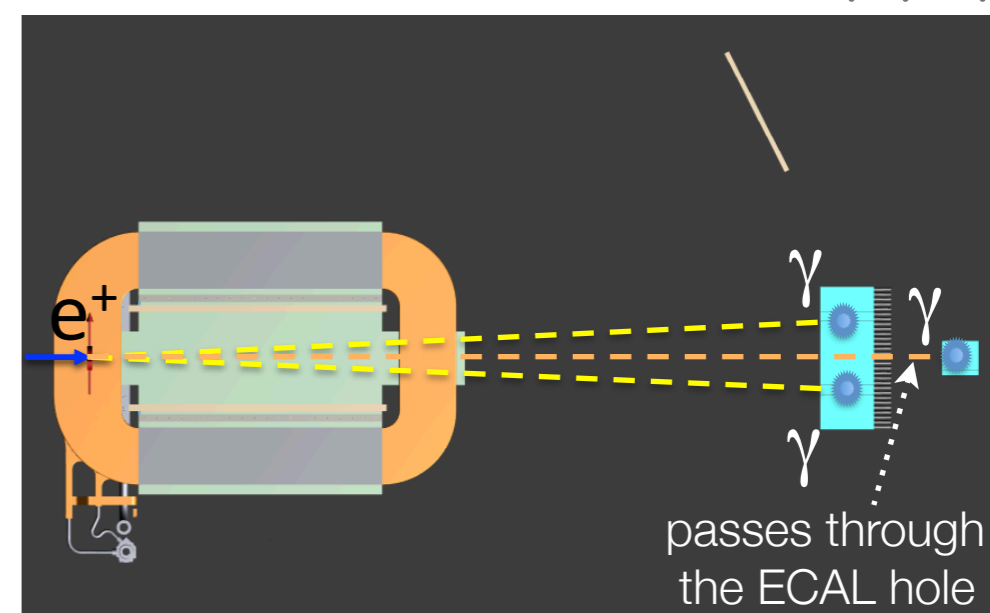

Bremsstrahlung: $e^+ N \rightarrow e^+ N \gamma$

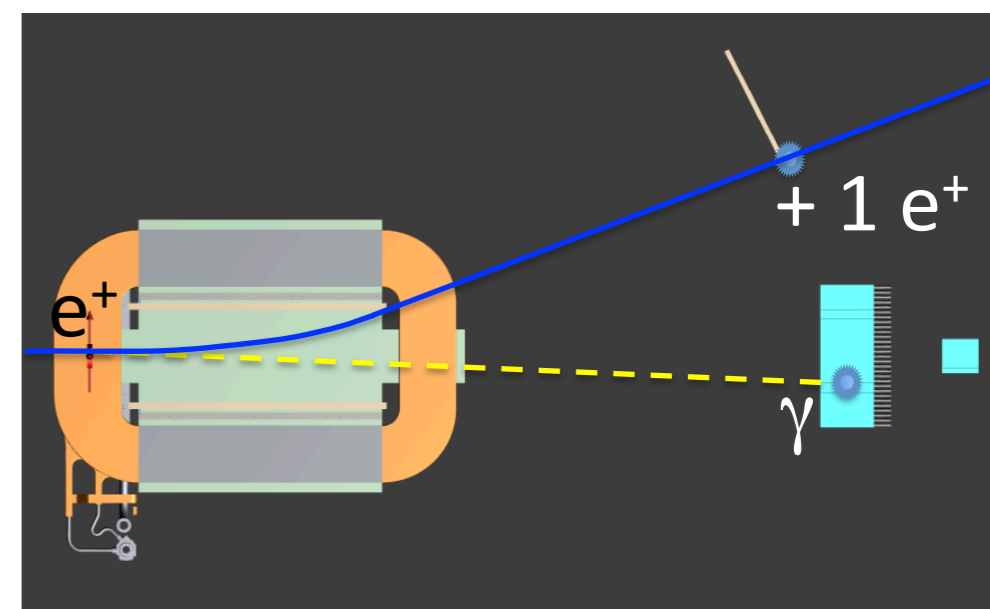

Sensitivity

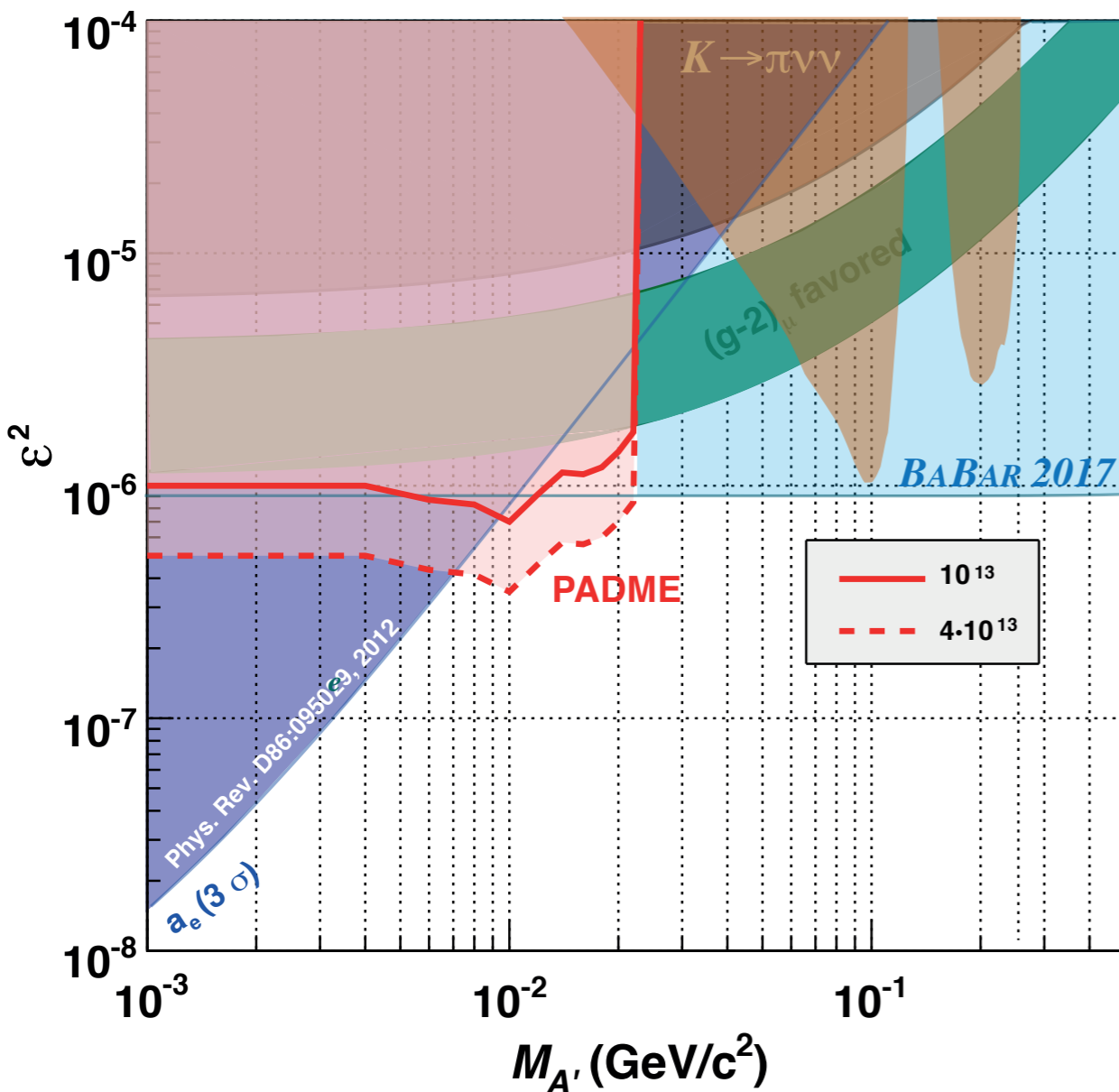

Based on $2.5 \cdot 10^{10}$ fully GEANT4 simulated 550 MeV e^+ on target events.
 Number of BG events is extrapolated to 10^{13} e^+ on target.

PADME can explore in a model-independent way the region down to $\epsilon \approx 10^{-3}$ w/:

- $m_{A'} < 23.7$ MeV ($E_{\text{beam}} = 550$ MeV)
- $m_{A'} < 27.7$ MeV ($E_{\text{beam}} = 750$ MeV)
- $m_{A'} < 32$ MeV ($E_{\text{beam}} = 1$ GeV)

Jan	Feb	Mar	Apr	May	Jun	Jul	Agu	Sep	Oct	Nov	Dec
Commissioning			PADME run 1				DAΦNE			run 1	

2018

Conclusions

- Dark Photon (DP) is predicted in a class of relatively young and general new physics models which are quickly gaining interest in the DM community
- A DP that decays into DM can (partially) explain the $(g-2)_\mu$ discrepancy
- PADME is an experiment that will search for an “invisible” (DM) decaying DP at the Laboratori Nazionali di Frascati
- The collaboration aims to collect 10^{13} e^+ on target by the end of 2018 testing, in a model-independent way, a DP w/ $\varepsilon \gtrsim 10^{-3}$ and mass up to 23.7 MeV ($E_{\text{beam}} = 550$ MeV)
- PADME results will apply also to other hypothetical particles like Axion Like Particles and Dark Higgs

References

- Dark Photon
 - P. Galison and A. Manohar, Phys. Lett. B 136, 279 (1984)
 - B. Holdom, Phys. Lett. B 166, 196 (1986)
- Dark Photon and $(g-2)_\mu$ anomaly
 - M. Pospelov, Phys. Rev. D 80, 095002 (2009)
 - J. P. Lees et al., arXiv:1702.03327 (2017)
- Dark Photon research status and perspectives
 - M. Raggi and V. Kozhuharov, Riv. Nuovo Cim. 38 , 449 (2015)
 - J. Alexander et al., arXiv:1608.08632 (2017)
- LNF Beam Test Facility
 - G. Mazzitelli et al., Nucl. Instrum. Meth. A 515, 524 (2003)
- PADME
 - M. Raggi and V. Kozhuharov, AdHEP 2014 , 959802 (2014)
 - M. Raggi, V. Kozhuharov and P. Valente, EPJ Web Conf. 96 , 01025 (2015)

Backup

Dark Photon searches



PADME visible

Thanks to granular e^+/e^- vetoes it is possible to search for (short lived) A' visible decaying in visible w/ the current setup

Possible future upgrades:

- high z thin target (increased A' bremsstrahlung)

- $E_{A'}$ can be $> \sqrt{2}m_e E_{\text{beam}}$
- $E_{A'}$ unknown (no closed kinematics)

Only visible decays are interesting

Bremsstrahlung

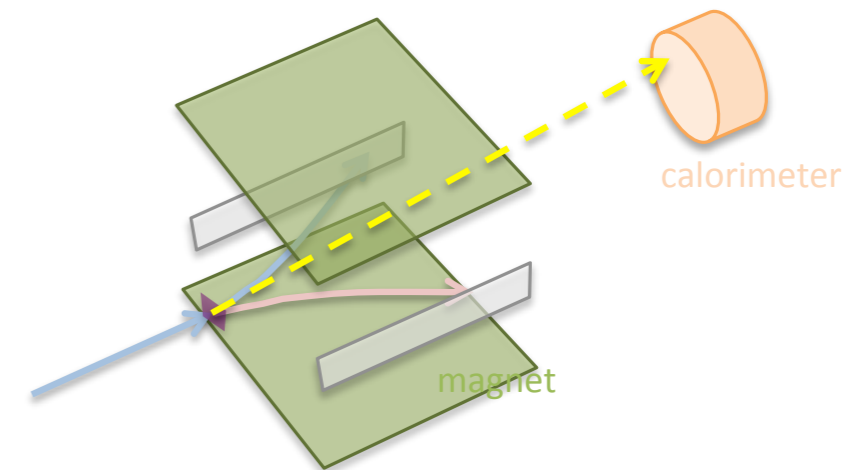
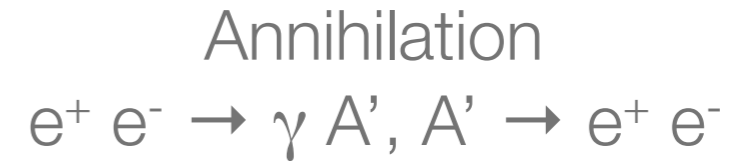
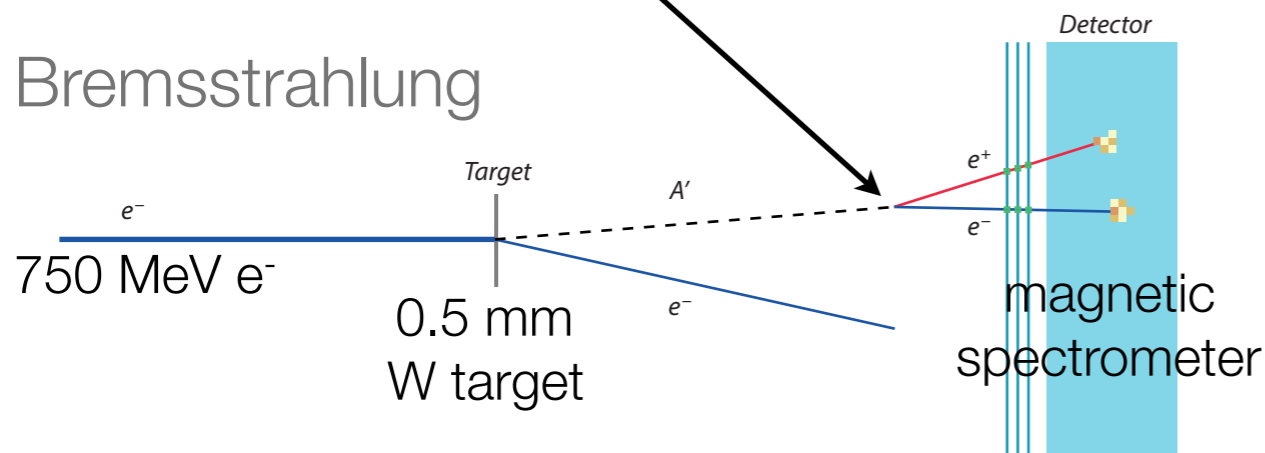

Backgrounds

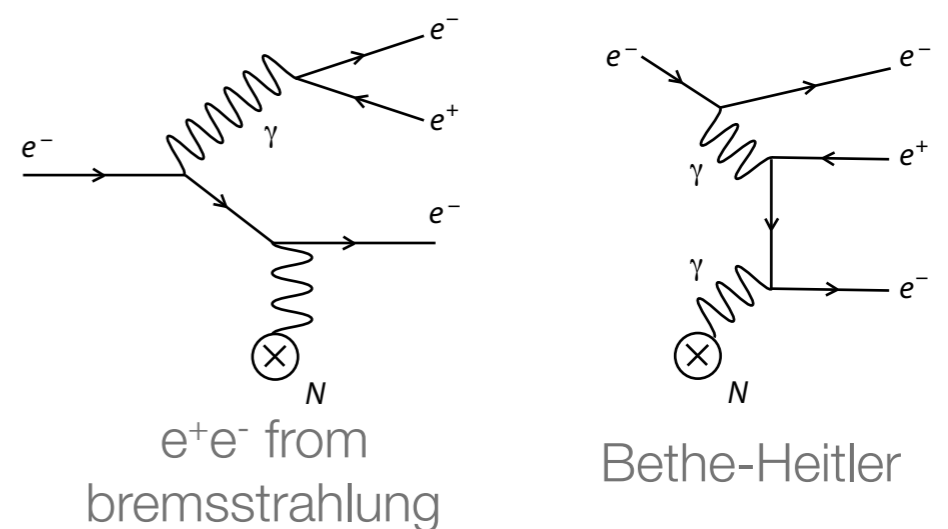

Preliminary calculations w/ 10^{18} EOT give a sensitivity on $\epsilon^2 \sim 10^{-7}$ in the low mass region, that worsens as $m_{A'}$ increases

Dark Higgs at PADME

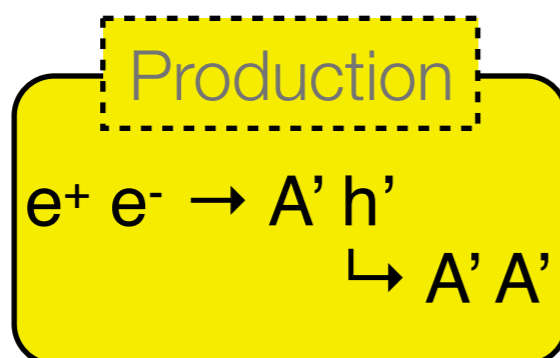

Interesting decay for PADME (depending on $m_{h'}$ and $m_{A'}$):

- if $m_{A'} < m_{h'}/2$ dominant $A' h' \rightarrow A' A' A' \rightarrow 6$ leptons (0 charge, $E_{\text{tot}} < E_{\text{beam}}$)
- if $m_{A'} > m_{h'}/2$ (or h' long lived) dominant $A' h' \rightarrow A' \text{inv.} \rightarrow 2$ leptons (0 charge)

Limits on Dark Higgs

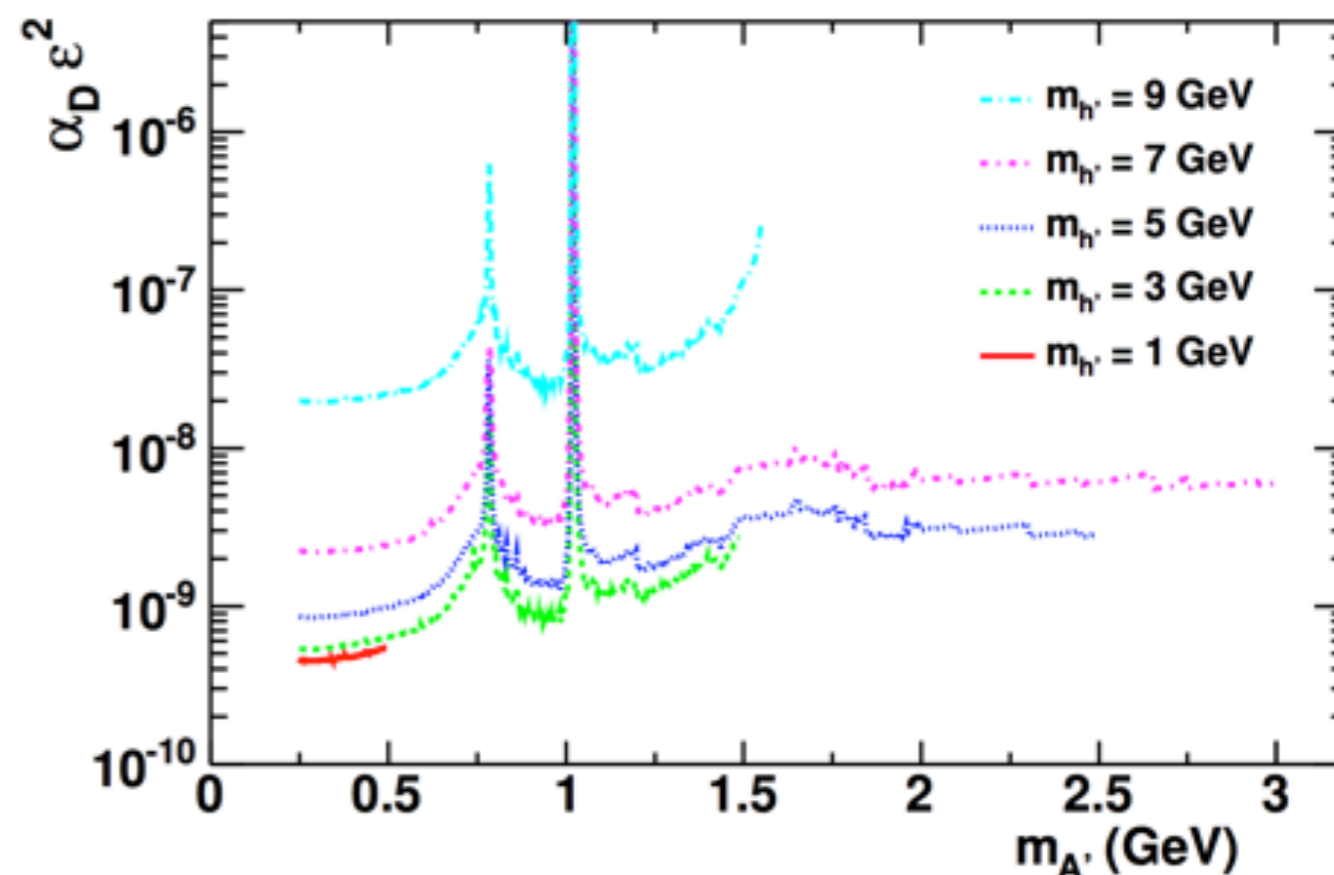

- • strong signature (no new detector component needed)
- • tracking spectrometer needed

Axion Like Particles at PADME

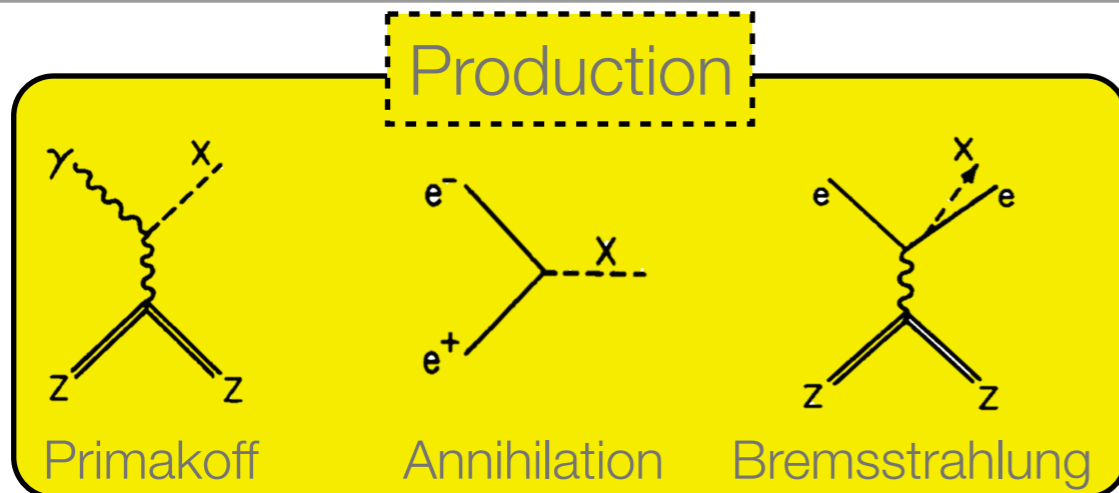

An invisible decaying or long lived ALP in PADME has the same signature of a DP:

- 1γ
- missing energy in the final state

In the visible decay $a \rightarrow \gamma \gamma$ all the production mechanisms can be explored up to $m_{ALP} \sim 100$ MeV.

Observables:

- $e^+ \gamma \gamma$
- $\gamma \gamma \gamma$

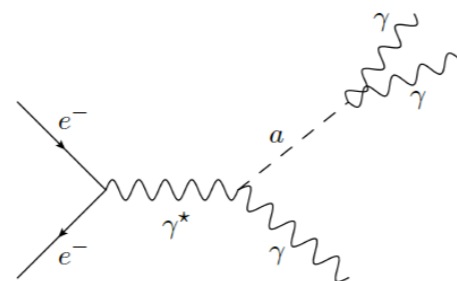

Limits on ALPs coupling to photons

