

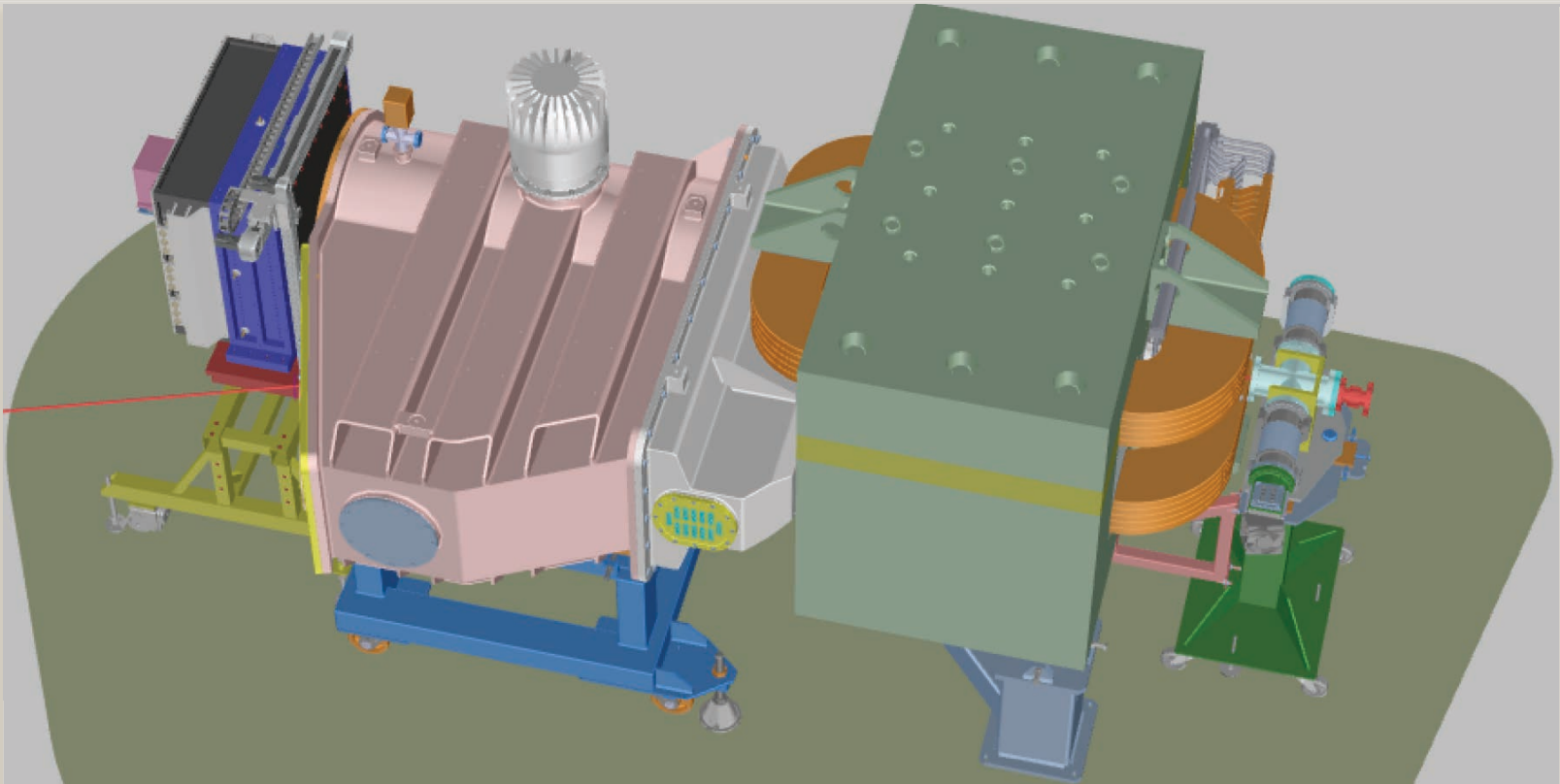

The **PADME** experiment



Dr. M. Raggi

Sapienza University of Rome & INFN Roma1
on behalf of the **PADME** collaboration

Vulcano Workshop 2018 –

Frontier Objects in Astrophysics and Particle Physics

What is the universe made of?

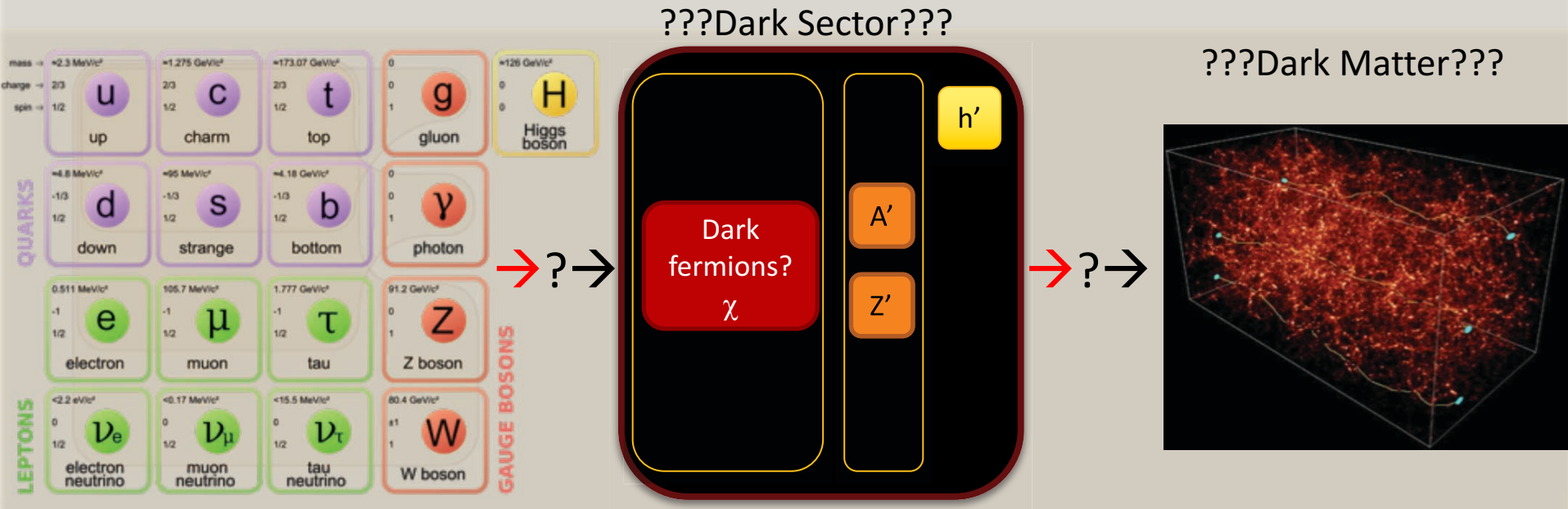

- Standard model only includes <20% of the matter in the universe
 - We only know dark matter interact gravitationally
- Many open questions
 - What is dark Matter made of?
 - How dark matter interact, if it does, with SM particles?
 - Does one or more new dark force exist?
 - How complex is the dark sector particles spectrum?

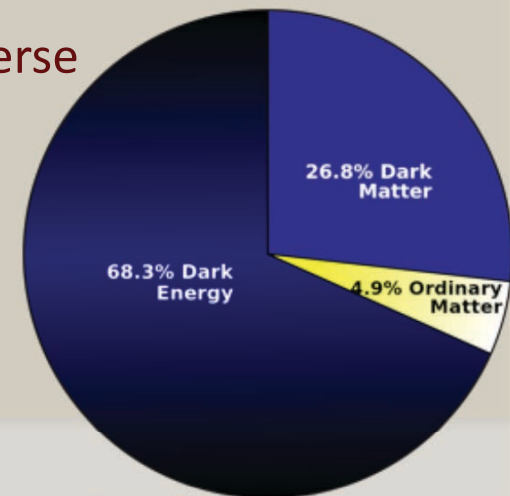

DM, dark sectors and portals

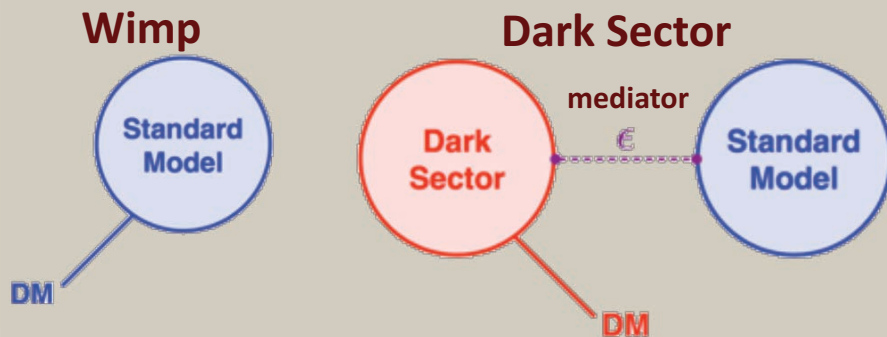

Dark (or hidden) sector:

DM particles **completely neutral** under SM forces, with **new interactions**

Mediator:

A **mediator particle** of the **new interaction**, interacting **very weakly** with SM particles

Portal interaction:

New interaction connecting dark mediator and SM particles

- The mediator can be scalar, fermion, **vector**, axion...
- The relic dark matter (DM) can be **either** the mediator particle **or** just coupled to SM via a hidden interaction
- Different portals can **co-exist**: e.g. dark photon and Higgs, or dark photon and axion
- Dark sectors invoked not only for the DM problem, but also for solving other puzzles:
 - **Muon $g-2$ anomaly**, proton radius, inflation, **^8Be anomaly**, ...
- The **vector portal is the simplest** both from the theory [additional U(1) gauge symmetry] and experiment point of view [just replace an ordinary γ with a dark one in any QED processes]
- **Wide mass and coupling ranges allowed**

Where to search for a new mediator?

Dark Sector Candidates, Anomalies, and Search Techniques

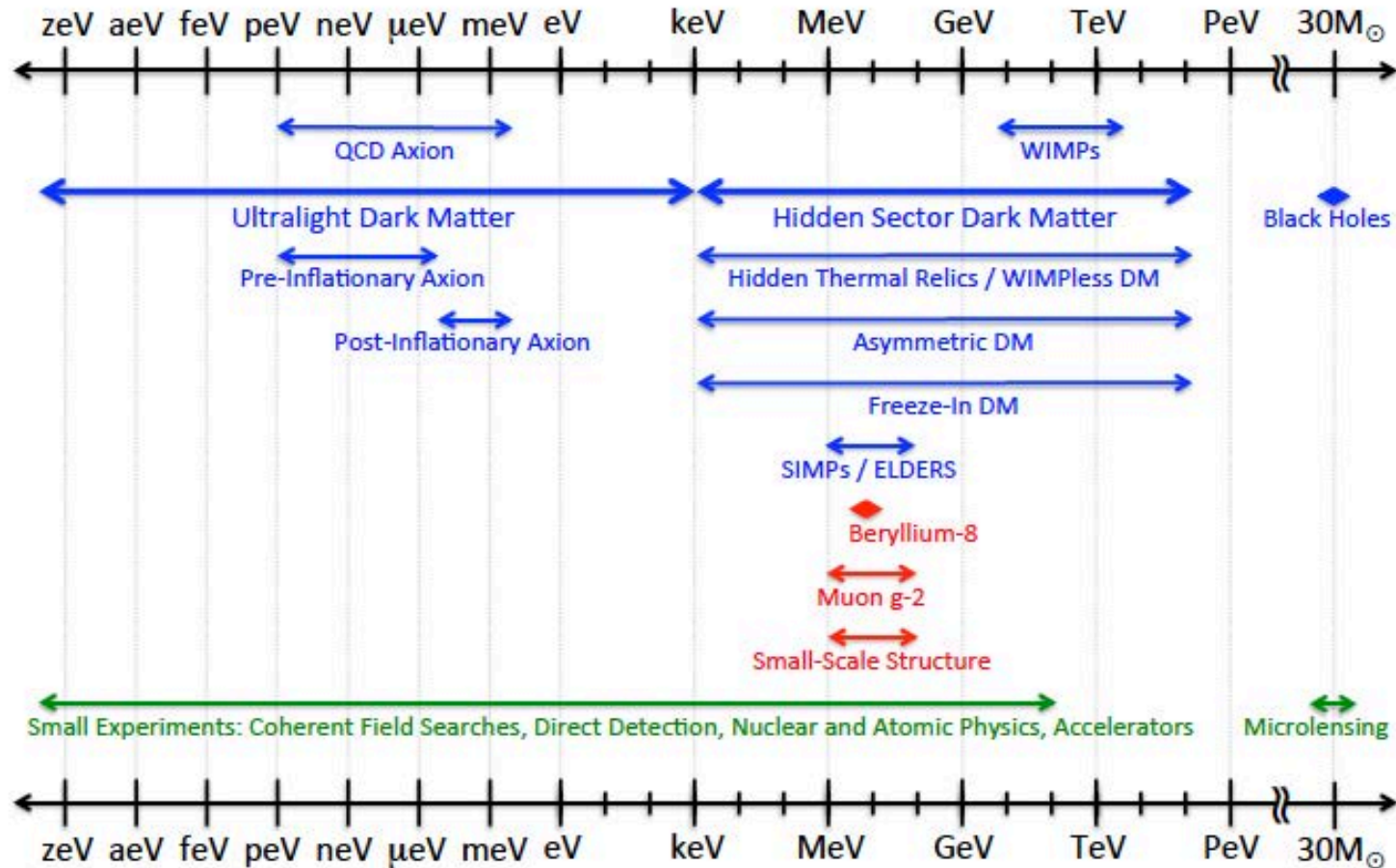

A' production and decays

□ A' can be produced in e^+ collision on target by:

- ◆ Bremsstrahlung: $e+N \rightarrow e+NA'$
- ◆ Annihilation: $e+e^- \rightarrow gA'$
- ◆ Meson decays

□ If no dark matter candidate lighter than the A' boson exists:

- ◆ $A' \rightarrow e^+e^-, \mu^+\mu^-, \text{hadrons}$, “visible” decays
- ◆ For $M_{A'} < 210 \text{ MeV}$ A' only decays to e^+e^- with $\text{BR}(e^+e^-)=1$

□ If any dark matter particle χ with $2M_\chi < M_{A'}$ exists

- ◆ A' will dominantly decay into pure DM
- ◆ $\text{BR}(\ell^+\ell^-)$ suppressed by factor ε^2
- ◆ $A' \rightarrow \chi\chi \sim 1$. These are the so called decays to “invisible”

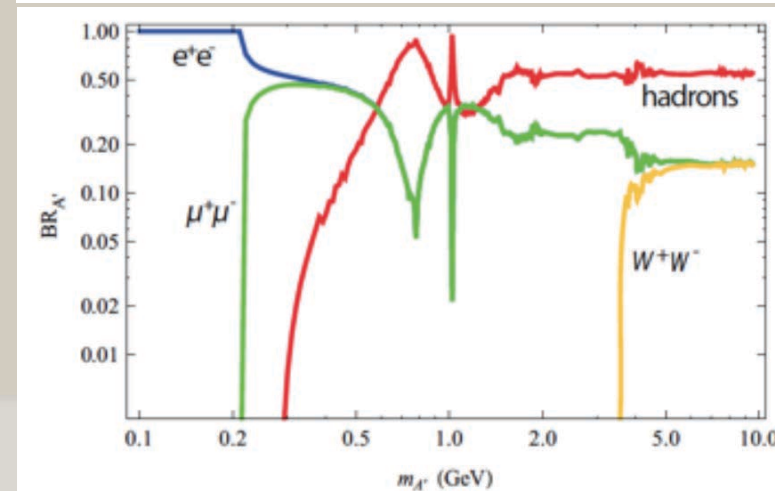
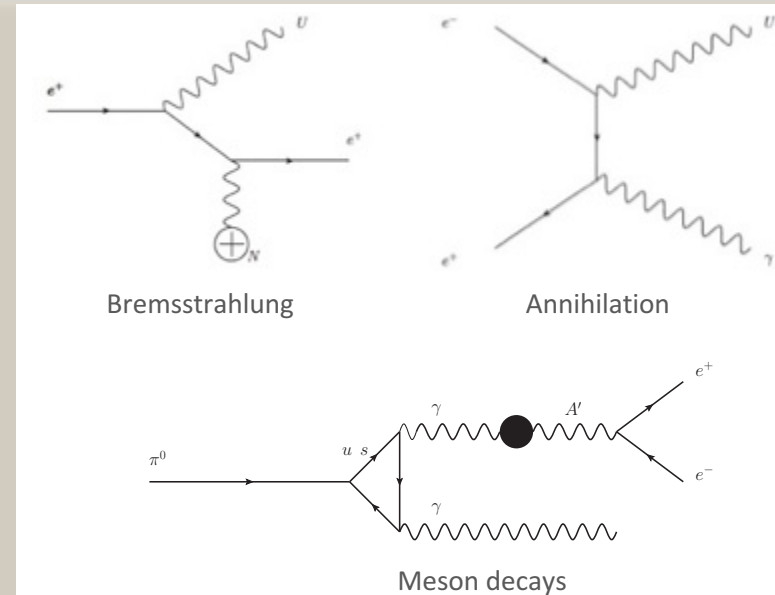

A' experiments at accelerators

visible decays ($A' \rightarrow \ell^+ \ell^-$)

Dump experiments

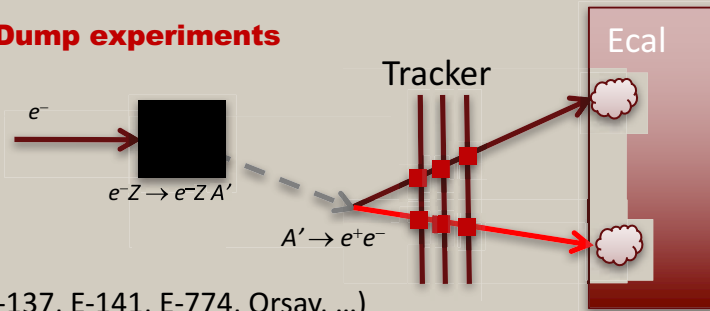

(E-137, E-141, E-774, Orsay, ...)

Thin target experiments

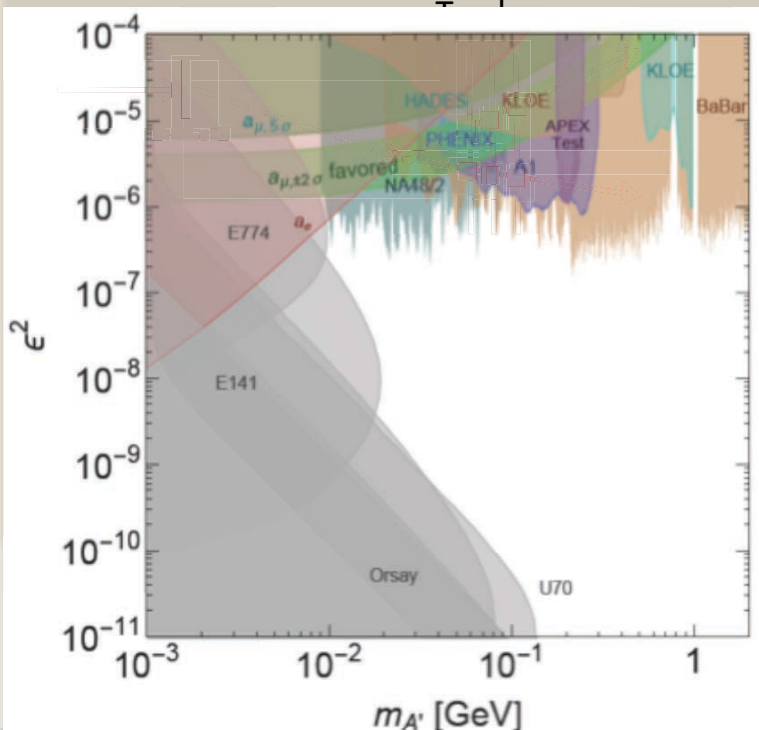

invisible decays ($A' \rightarrow \chi\chi$)

Dump+recoil

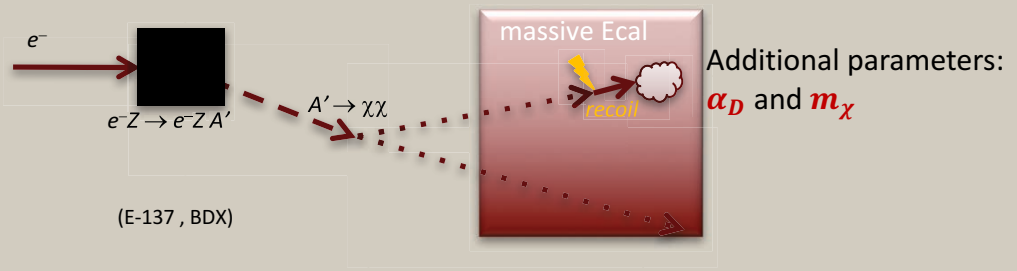

(E-137, BDX)

Additional parameters:
 α_D and m_χ

Missing energy ($E_D \ll E_{\text{beam}}$)

Missing momentum ($p_2 \ll p_{\text{beam}}$)

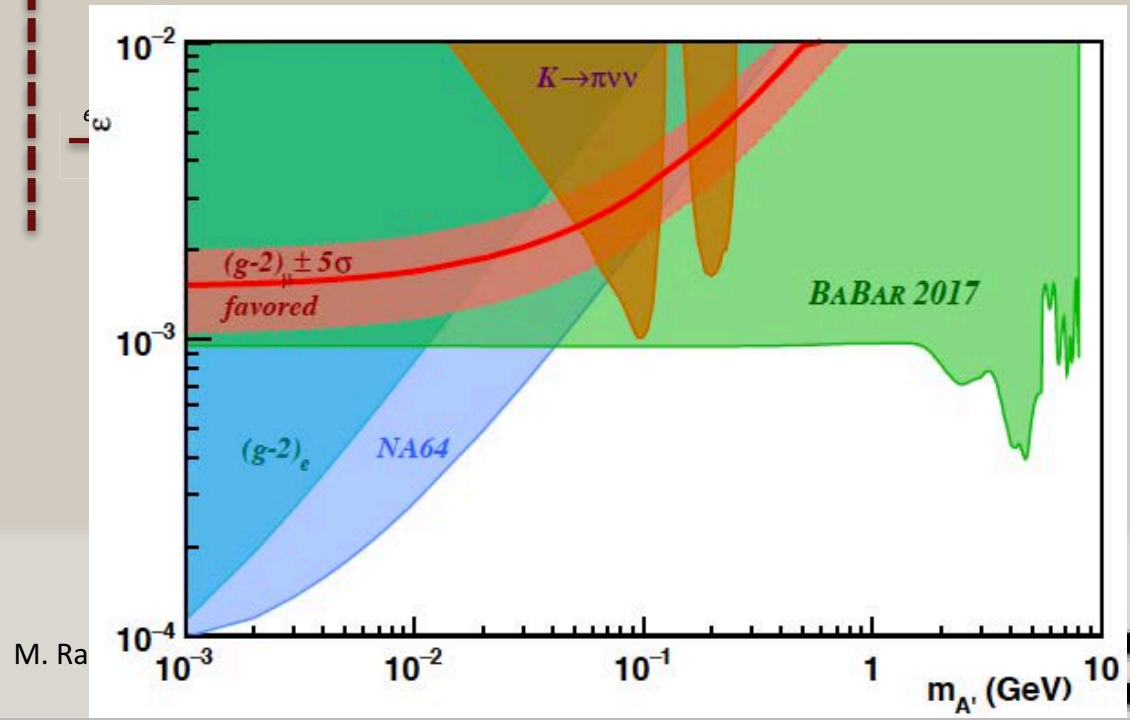

How to search for invisible decays?

Positive evidence

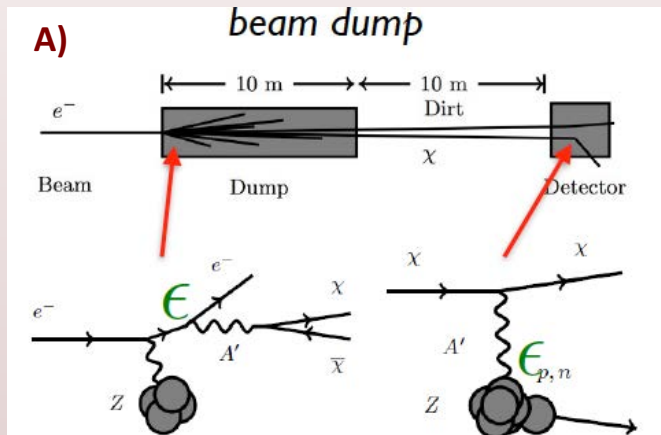

$$N \propto \epsilon^4 \sim 10^{20} \text{ EOT } (\alpha_D \text{ and } \epsilon^2)$$

C) Missing Mass

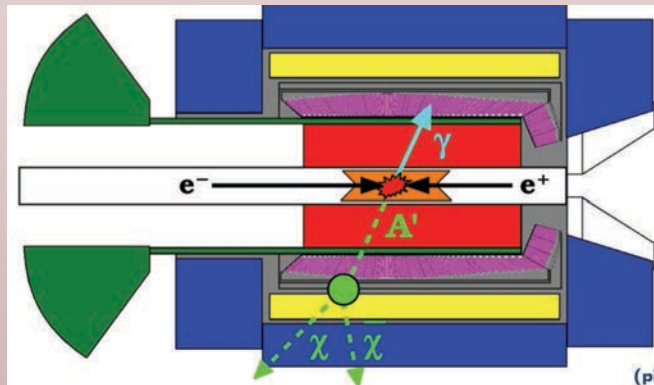

$$N \propto \epsilon^2 \text{ sensitive to } (\epsilon, A') \text{ mass}$$

Limited by $M_{A'} < \sqrt{2m_e \cdot E_B}$

Negative evidence

Missing energy

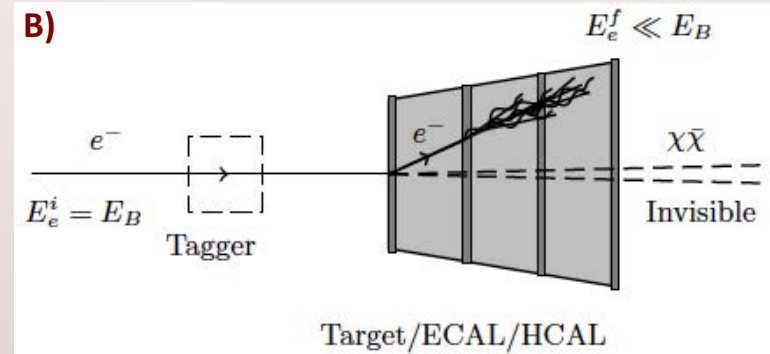

$$N \propto \epsilon^2 (\epsilon^2 \text{ only})$$

D) missing momentum

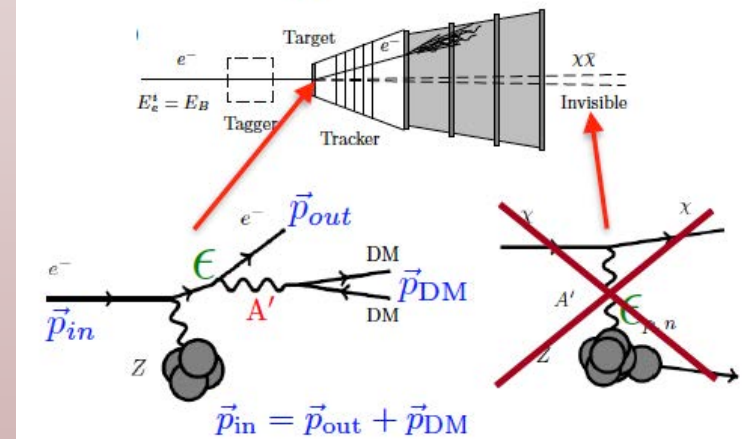

$$N \propto \epsilon^2 \text{ contains } E_{\text{miss}} \text{ exp.}$$

The PADME physics case(s)

PADME is a multipurpose dark sector search experiment with positrons on fixed target able to detect photons and charged particles:

Main goal: **Invisible dark photon decays $A \rightarrow \chi\chi$**

Aims to use annihilation production and missing mass searches. Several physics case under analysis

Dark Photon arXiv:1707.04591v1

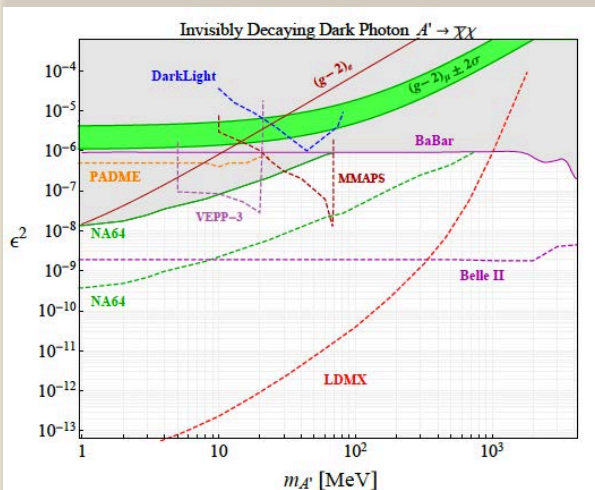

Invisible final state $A' \rightarrow \chi\chi$
(γ +missing mass)

ALPs and g-2 PRD 94, 115033,2016

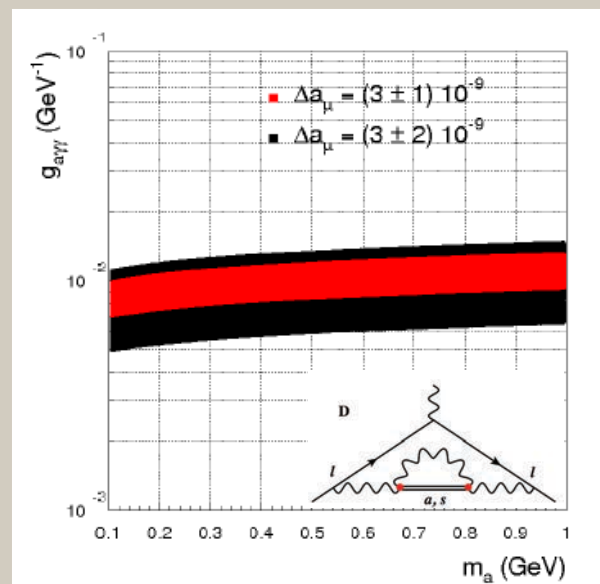

ALPs final state $a \rightarrow \gamma\gamma$
($\gamma\gamma\gamma$ or $e\gamma\gamma$)

Fifth force PRL 117, 071803 (2016)

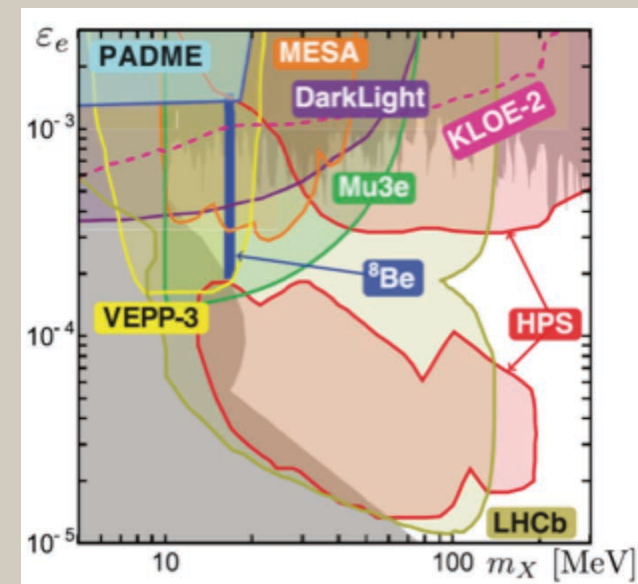

Final state $X \rightarrow e^+e^-$

Why missing mass technique?

- The missing mass technique represents a unique opportunity:
 - Independent of the A' decays and dark sector structure (α_D, M_χ) just ϵ^2 and $M_{A'}$ parameter explored!
 - Very clean signature for positive evidence (mass peak!)
 - Measure mass and coupling at the same time!
 - Theoretically clean (no dependence on missing energy and shower modelling)
 - Cross section enhanced for $m_{A'} \sim \sqrt{s}$
(complementary to bremsstrahlung production decreasing for high $m_{A'}$)
 - Searching for positive evidence is a great opportunity for PADME (ALPs, Dark Higgs)

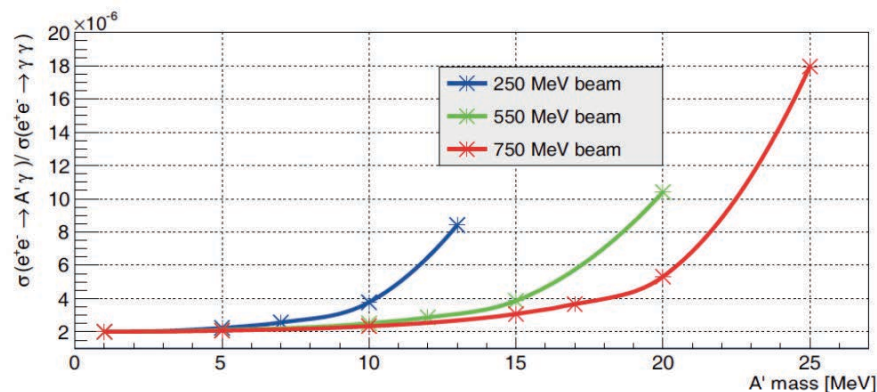

$$\frac{d\sigma(e^+e^- \rightarrow \gamma A')}{d\cos\theta} = \frac{\alpha\epsilon^2}{2s^2(s - m_{A'}^2)} \left(\frac{s^2 + m_{A'}^4}{\sin^2\theta} - \frac{(s - m_{A'}^2)^2}{2} \right)$$

$M_{A'} \rightarrow 0$

$$\sigma(e^+e^- \rightarrow \gamma A') = 2\epsilon^2\sigma(e^+e^- \rightarrow \gamma\gamma).$$

$$\frac{\sigma(e^+e^- \rightarrow U\gamma)}{\sigma(e^+e^- \rightarrow \gamma\gamma)} = \frac{N(U\gamma)}{N(\gamma\gamma)} * \frac{Acc(\gamma\gamma)}{Acc(U\gamma)} = \epsilon^2 * \delta,$$

The DAΦNE Beam Test Facility (BTF)

	Electrons	Positrons
Maximum beam energy (E_{beam})[MeV]	750 MeV	550 MeV
Linac energy spread [Dp/p]	0.5%	1%
Typical Charge [nC]	2 nC	0.85 nC
Bunch length [ns]	1.5 – 40 (can reach 200 in 2016)	
Linac Repetition rate	1-50 Hz	1-50 Hz
Typical emittance [mm mrad]	1	~1.5
Beam spot s [mm]	<1 mm	
Beam divergence	1-1.5 mrad	



- Able to deliver both electrons and positrons of tuneable E
 - Duty cycle 50 bunch x 40-200 ns = $2 \times 10^{-6} - 1 \times 10^{-5}$ s
 - Precise energy tuning down to 100 MeV
 - Low emittance beam

The PADME experiment at the BTF

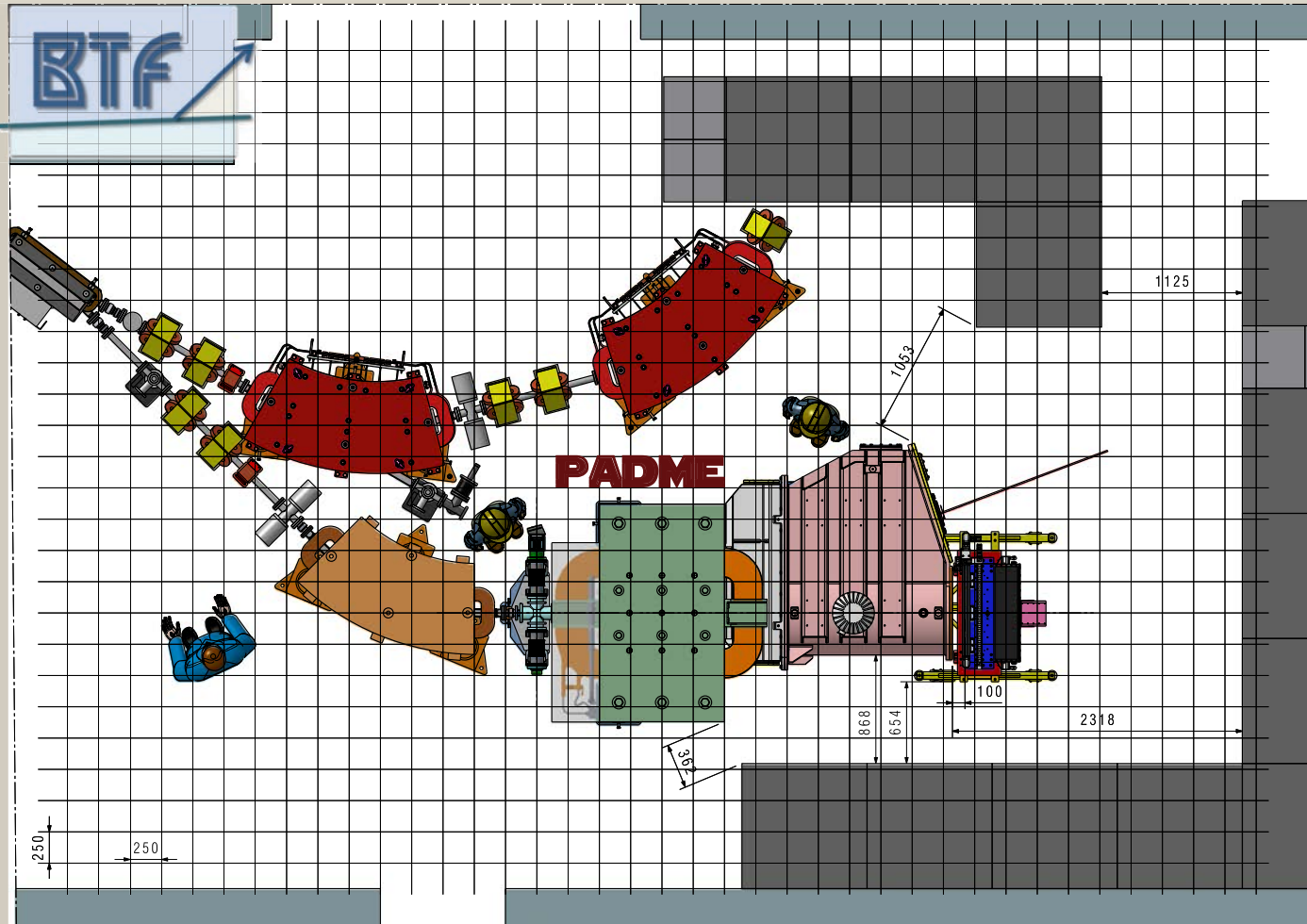

PADME experiment setup

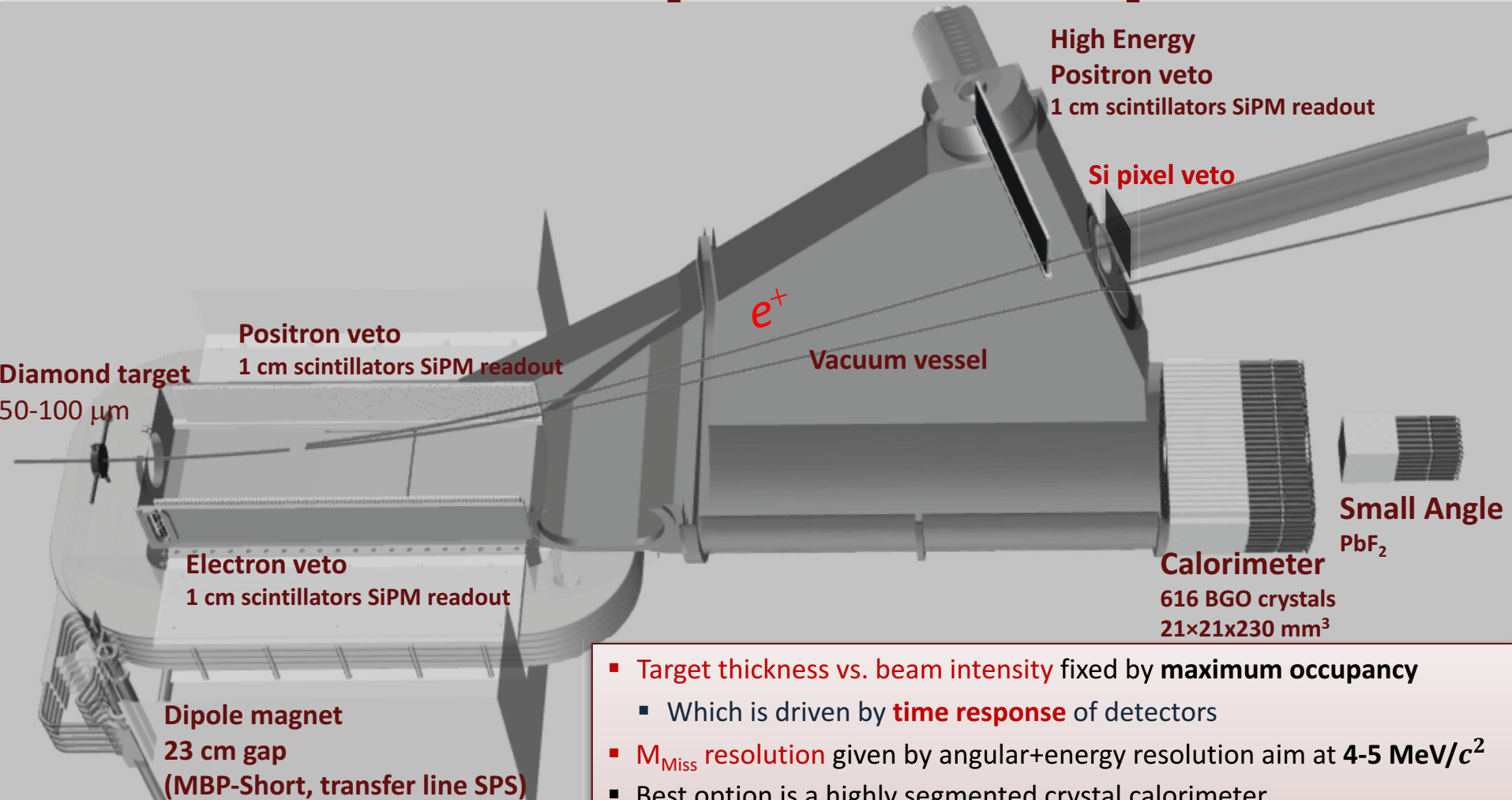

- **Target thickness vs. beam intensity** fixed by **maximum occupancy**
 - Which is driven by **time response** of detectors
- **M_{Miss} resolution** given by angular+energy resolution aim at **4-5 MeV/c^2**
- Best option is a highly segmented crystal calorimeter
 - **Crystal size $21 \times 21 \times 230 \text{ mm}^3$** fixed by Molière radius
 - **Calorimeter size** fixes the number of crystals
 - Distance + dipole **gap** fixes the **acceptance**
 - Hole in BGO calorimeter + small angle fast detector to cope with rate
- Everything in **vacuum to avoid e^+ interaction outside the target**

PADME invisible technique: $A \rightarrow \chi\chi$

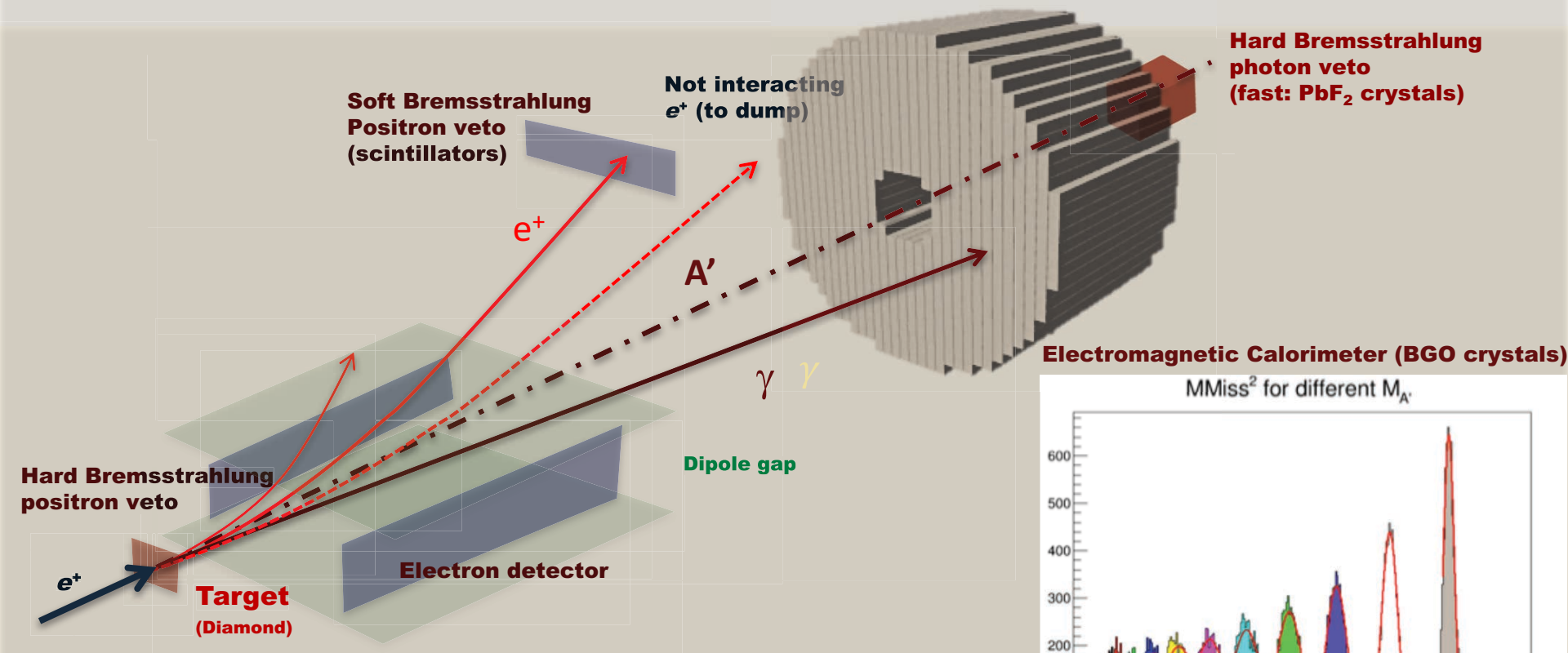

Electromagnetic Calorimeter (BGO crystals)

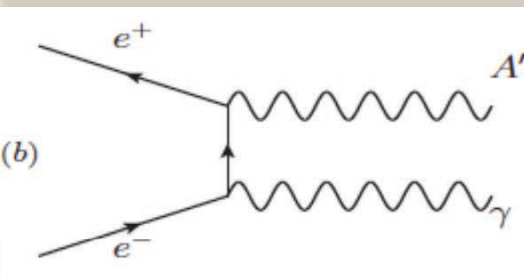
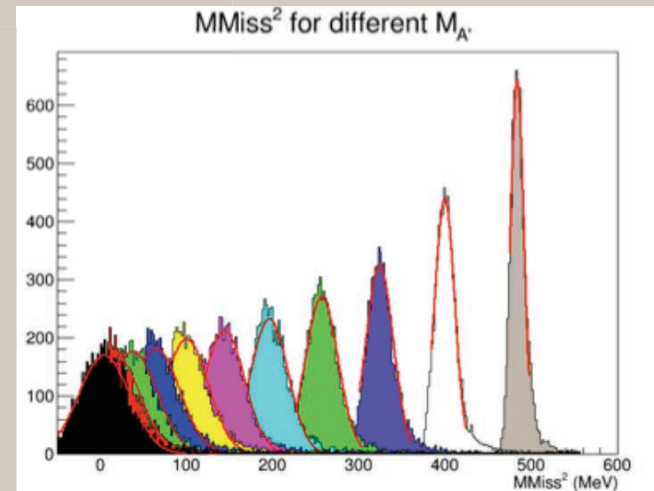

PADME visible technique: $A' \rightarrow e^+e^-$

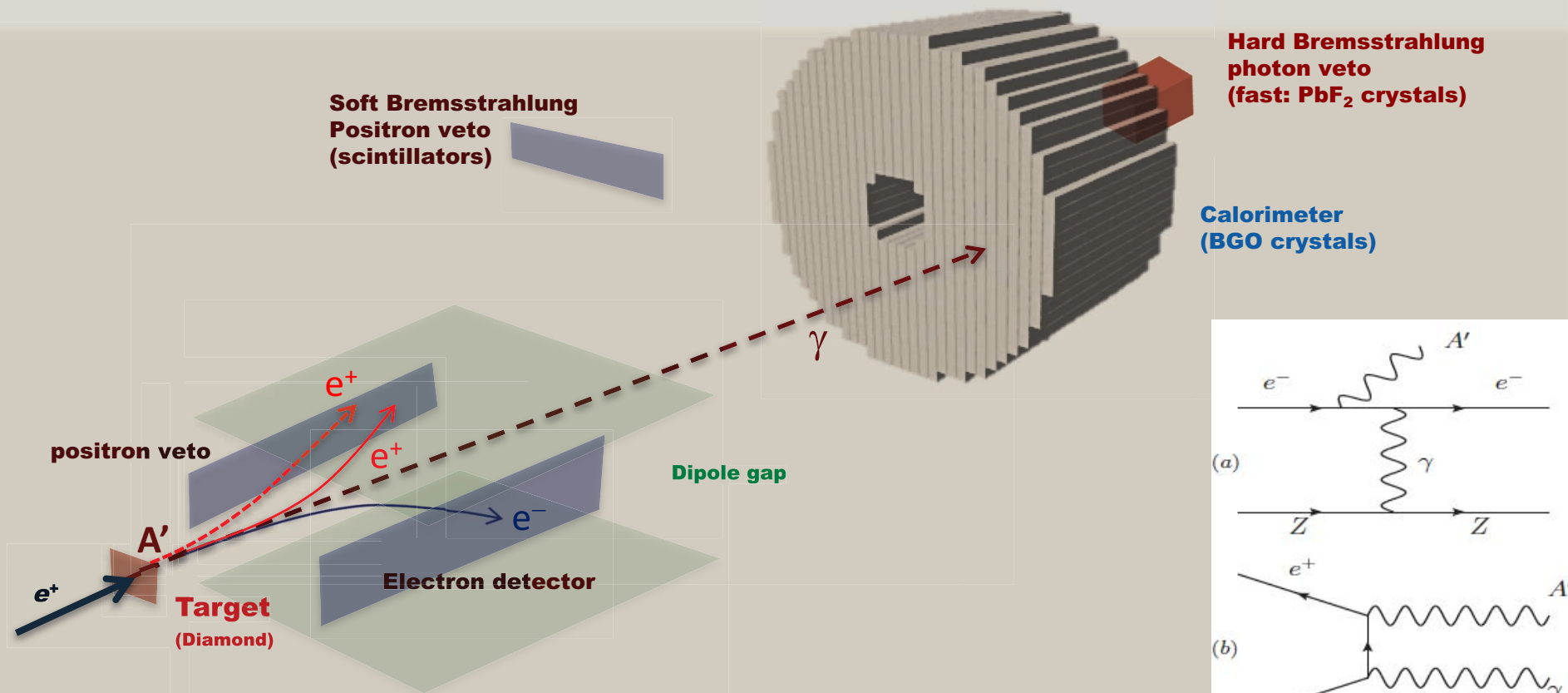

Three different final states can be explored using 3 different production

- a) Final state A' -strahlung: $e^+e^-e^+$
- b) Annihilation in 2γ final state: $e^+e^-\gamma$
- c) Final state: e^+e^- (only for defined A' mass $\sqrt{2meE_B}$)

PADME GEANT4 Monte Carlo

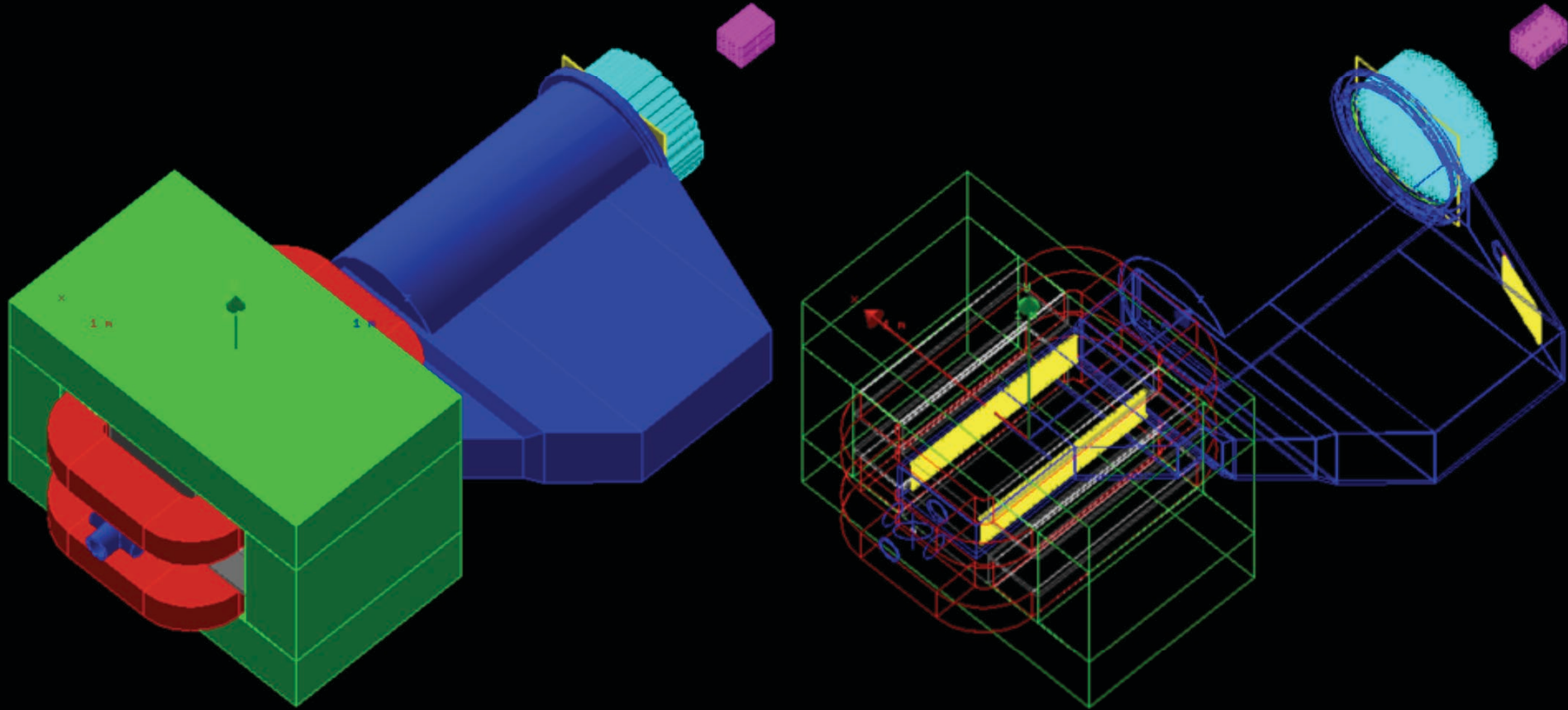

- Full description of the detector achieved including passive materials
- **New sensitivity estimate ongoing**
- **Need theoretical guidance to study sensitivity non dark photon scenario:**
 - ALPs generators
 - X-Bosons optimization under study

A' to invisible sensitivity analysis

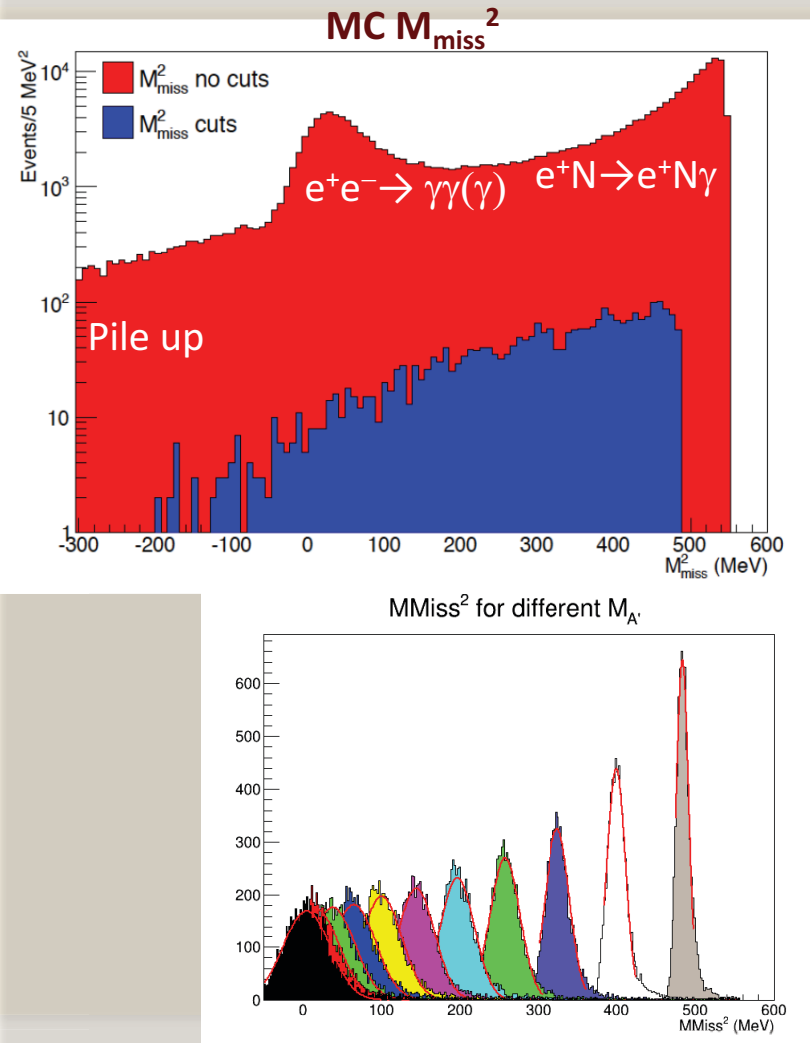

Candidate Signal selection

- Just one photon cluster in the ECal
- $30 \text{ mrad} < \theta_{\text{Cl}} < 65 \text{ mrad}$
- No tracks in the charged veto in within $\pm 2 \text{ ns}$
- No photons with $E_\gamma > 50 \text{ MeV}$ in within $\pm 2 \text{ ns}$ in the SAC
- Cluster Energy: $E_{\text{min}}(M_{A'}) < E_{\text{Cl}} < E_{\text{max}}(M_{A'}) \text{ MeV}$
- Missing mass in the region: $M_{A'}^2 \pm \sigma(M_{\text{miss}2})$

Search technique

- Count the number of BG events in each mass region from the blue distribution
- Consider them as A' candidate

PADME-invisible decay sensitivity

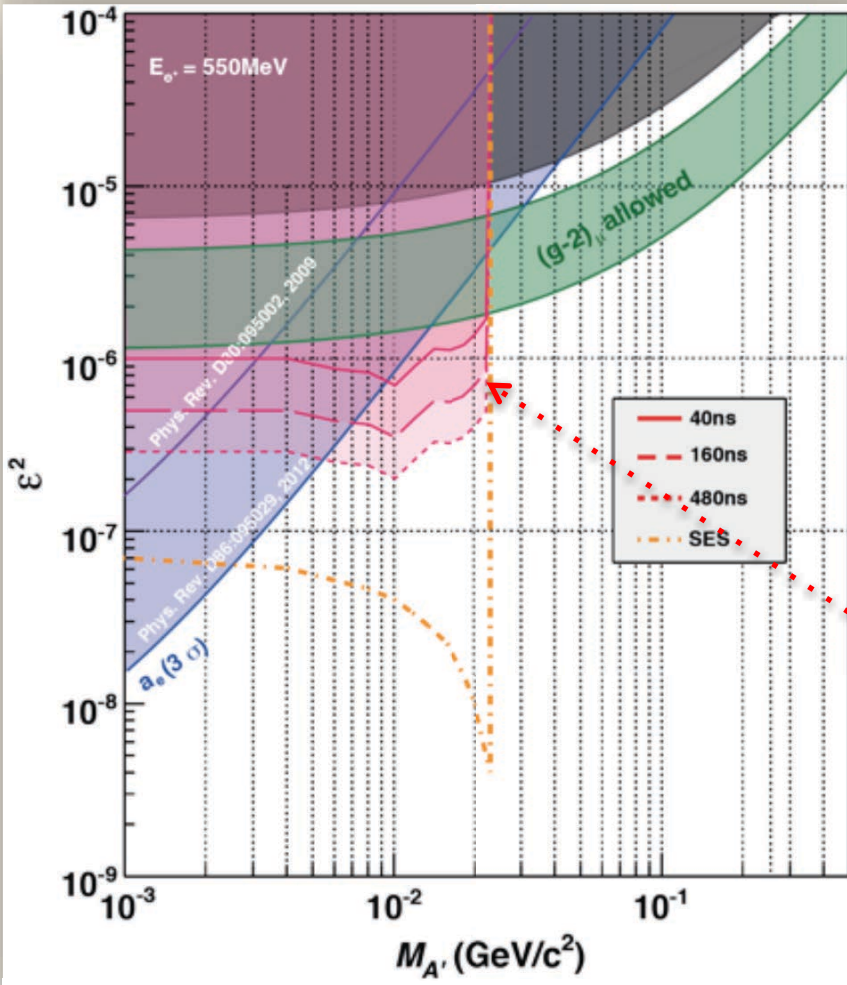

- Based on 2.5×10^{10} fully GEANT4 simulated 550 MeV e^+ on target events
 - Number of BG events is extrapolated to 1×10^{13} electrons on target
- Using $N(A'\gamma) = \sigma(N_{BG})$
- δ enhancement factor $\delta(M_{A'}) = \sigma(A'\gamma) / \sigma(\gamma\gamma)$ with $\varepsilon = 1$ due to A' mass

$$\frac{\Gamma(e^+e^- \rightarrow A'\gamma)}{\Gamma(e^+e^- \rightarrow \gamma\gamma)} = \frac{N(A'\gamma)}{N(\gamma)} \frac{Acc(\gamma\gamma)}{Acc(A'\gamma)} = \varepsilon \cdot \delta$$

PADME 2 years of data taking at 60% efficiency with bunch length of 200 ns
 4×10^{13} EOT = **20000** e^+ /bunch $\times 2 \times 3.1 \cdot 10^7$ s $\times 0.6 \cdot 49$ Hz

PADME single event sensitivity far to be reached improvement on the limits still possible.

$$E_{e^+} = 550 \text{ MeV: } M_{A'} < 23.7 \text{ MeV}/c^2$$

$$E_{e^+} = 750 \text{ MeV: } M_{A'} < 27.7 \text{ MeV}/c^2$$

$$E_{e^+} = 1 \text{ GeV: } M_{A'} < 32 \text{ MeV}/c^2$$

PADME detector status



Very fast PbF2 Cherenkov calorimeter for rejecting 2 and 3 photon background events and withstand Bremsstrahlung rate fast PMT readout



Spare dipole from CERN SPS (23 cm gap, 1 m long)



Scintillating bars with SiPM readout for rejecting Brems. background events (tagging positrons) Inside vacuum vessel

EM calorimeter BGO L3 crystals

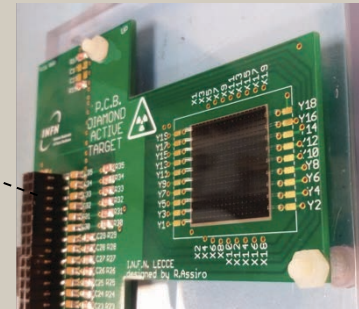
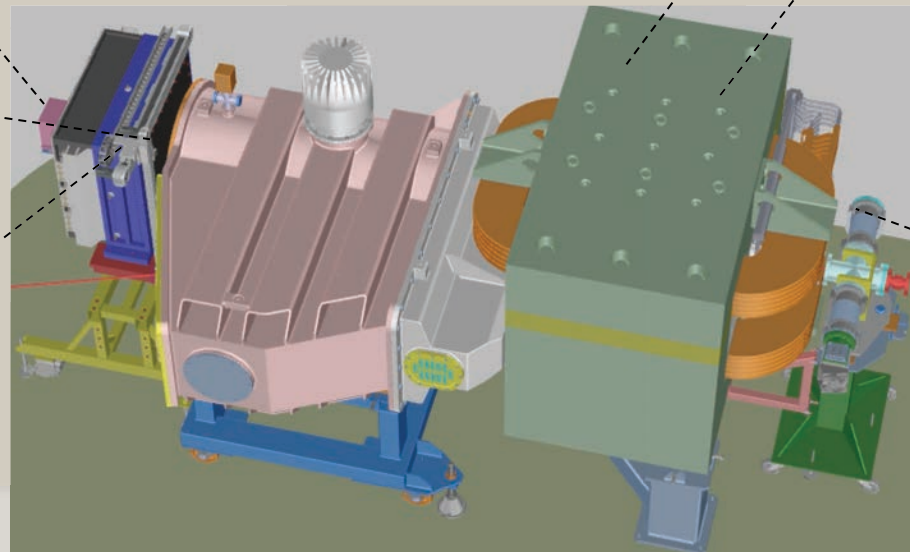

Diamond with graphite strips: All-Carbon active target, beam position & size and luminosity monitor.

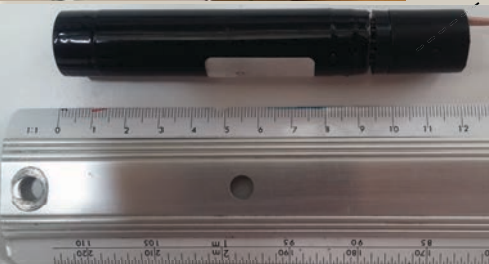

The PADME Ecal Status

Test each single crystal with a ^{22}Na source and 10 different PMT HV value to measure the crystals response curve. Compute the equalisation voltage.

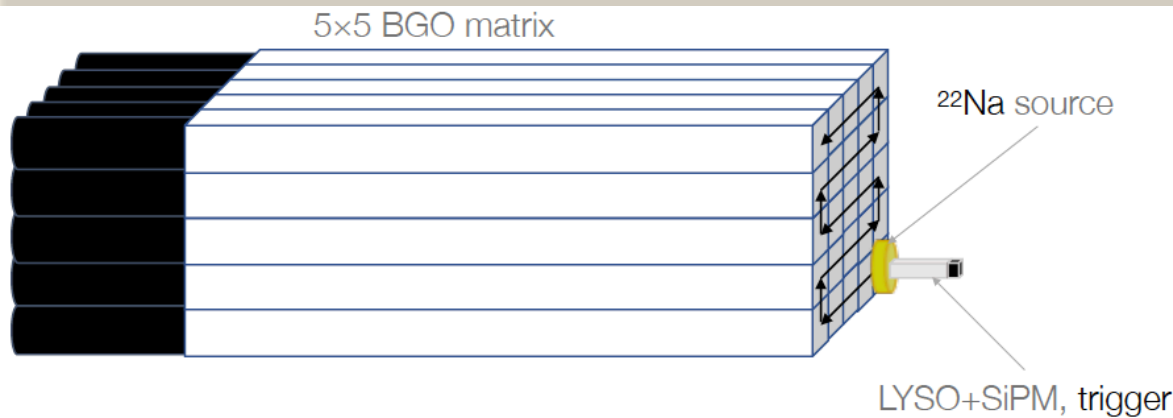

Ecal mechanics ready for assembly (moving at BTF next week)



More than 300 crystals already ~50% tested and ready to be assembled

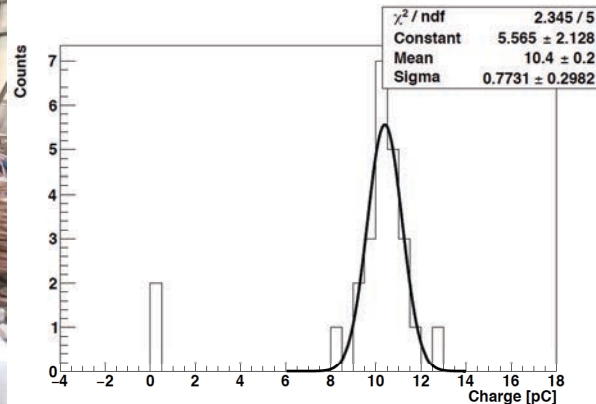

The PADME vacuum chamber

Inner chamber assembly at Fantini S.P.A



commissioning and running plans



2018

Jan	Feb	Mar	Apr	May	Jun	Jul	Aug	Sep	Oct	Nov	Dec
PADME Construction					Commissioning		PADME Run I				

Now

2019

Jan	Feb	Mar	Apr	May	Jun	Jul	Aug	Sep	Oct	Nov	Dec
Beam time for PADME to be negotiated with INFN and LNF management											

2018: commissioning and running

- PADME aims at collecting 1×10^{13} positrons on target **by the end of 2018**
- **Start of data taking for physics during July 2018**
- **Data 2018 collection**
 - Assuming a 65% eff. with 200 ns pulse length: $1.5 \text{E}7 \text{s} * 49 \text{pulses/s} * 2 \text{E}4 \text{e}^+/\text{pulse} * 0.65 = 10^{13} \text{e}^+ \text{ on target}$

ALPs physics at PADME

PADME can search for ALP having electron or photon couplings exploring different production mechanisms.

Bremsstrahlung

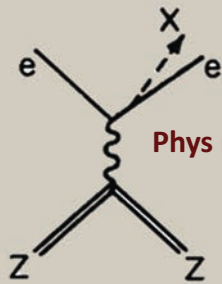

Annihilation

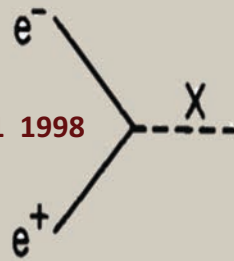

Primakoff

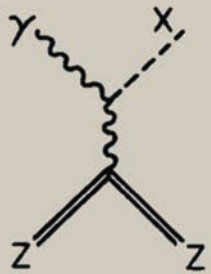

$\gamma\gamma$ Ann.

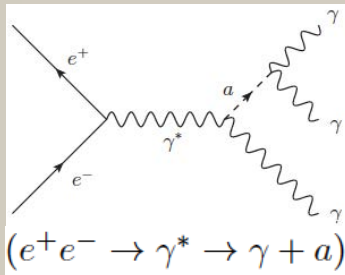

Photon fusion

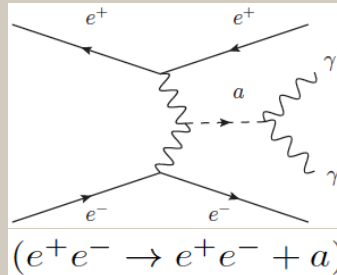

The observables at PADME might be:

Visible ALPs: $e^+\gamma\gamma$, $\gamma\gamma\gamma$, $e^+e^-\gamma\gamma$

Invisible ALPs: $\gamma + M_{\text{miss}}$, $e^+e^- + M_{\text{miss}}$

Limits on ALPs coupling to photons

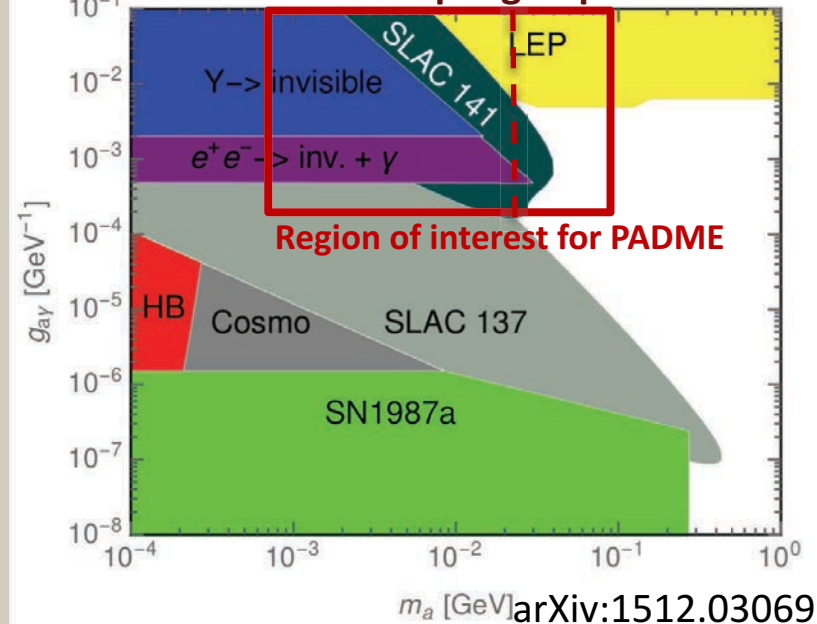

Invariant $\gamma\gamma$ in PADME MC 2x10¹⁰ 550MeV e⁺OT

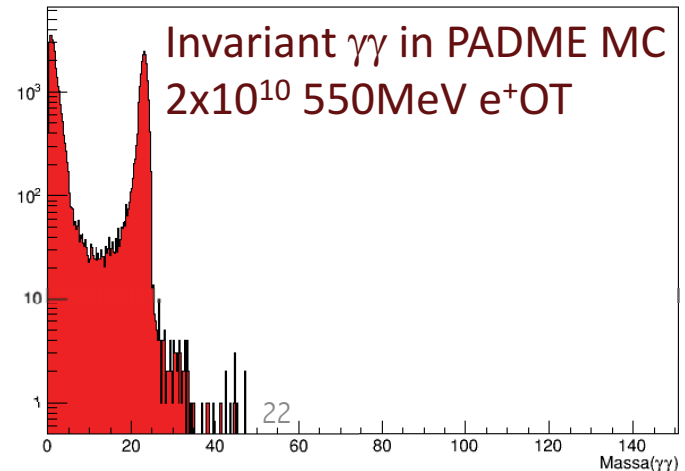

The ^8Be anomaly

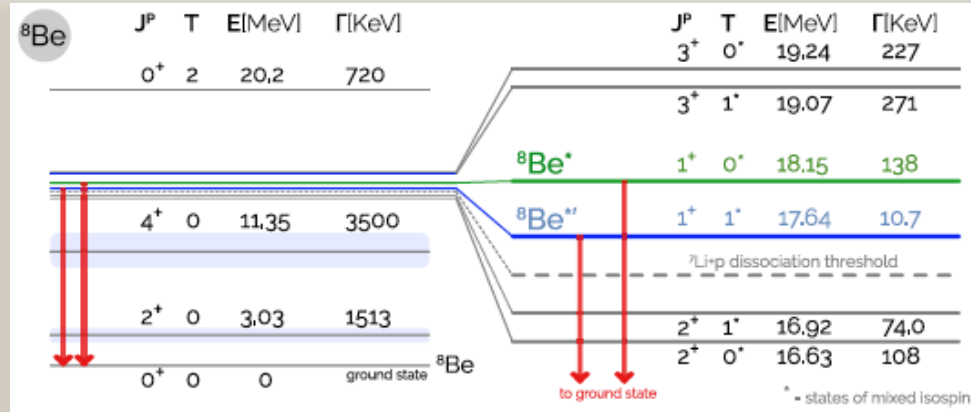
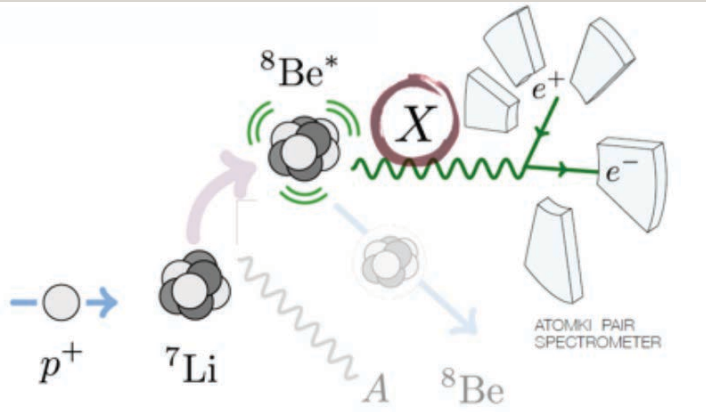

Is this an evidence of a new light dark photon?

Sanity checks performed

- Excess disappears as one scans through the proton beam resonance kinetic energy of 1.03 MeV
- excess becomes more pronounced when restricting to the subset of events with $E > 18$ MeV and is absent for lower energy events
- Excess only appears for events with symmetric E_{e^+} and E_{e^-}

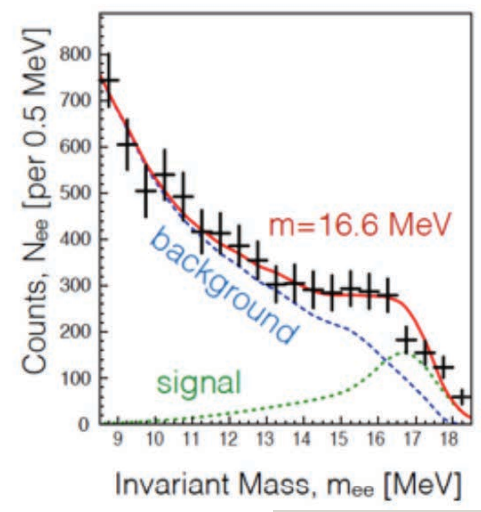
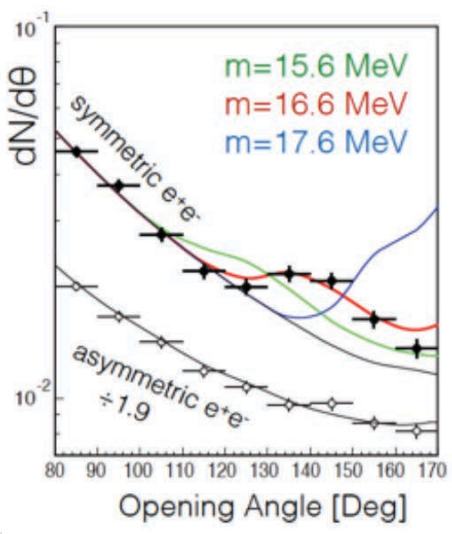

Can nuclear physics explain the anomaly observed in the internal pair production in the Beryllium-8 nucleus?

Xilin Zhang^{1,*} and Gerald A. Miller^{1,†}
¹Department of Physics, University of Washington, Seattle, WA 98195, USA
 (Dated: March 16, 2017)

Can only mitigate the anomaly by 1σ by improving nuclear treatment. [j.physletb.2017.08.013](https://arxiv.org/abs/1708.013)

$m_X = 16.7 \pm 0.35(\text{stat}) \pm 0.5(\text{sys}) \text{ MeV}$

The ^8Be anomaly interpretation

PRL 117, 071803 (2016)

PHYSICAL REVIEW LETTERS

WEEK ENDING
12 AUGUST 2016

Protophobic Fifth-Force Interpretation of the Observed Anomaly in ^8Be Nuclear Transitions

Jonathan L. Feng,¹ Bartosz Fornal,¹ Iftah Galon,¹ Susan Gardner,^{1,2} Jordan Smolinsky,¹ Tim M. P. Tait,¹ and Philip Tanedo¹

Protophobia

Equations (5) and (8) may be satisfied with a mild $\sim 10\%$ cancellation, provided the charges satisfy

$$-2.3 < \frac{\epsilon_d}{\epsilon_u} < -1.8, \quad -0.067 < \frac{\epsilon_p}{\epsilon_n} < 0.078. \quad (9)$$

Given the latter condition, we call the general class of vector models that can both explain the ^8Be anomaly and satisfy pion decay constraints “protophobic.”

Strongest experimental limit on the electron coupling comes from KLOE data: $\epsilon_e < 2E-3$

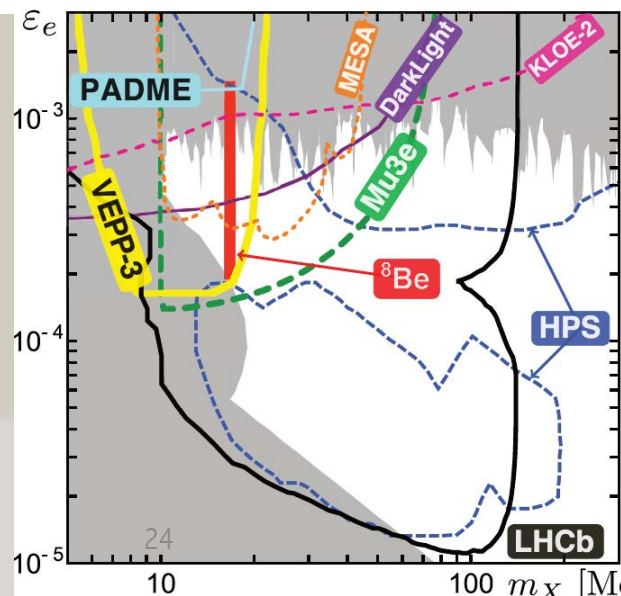
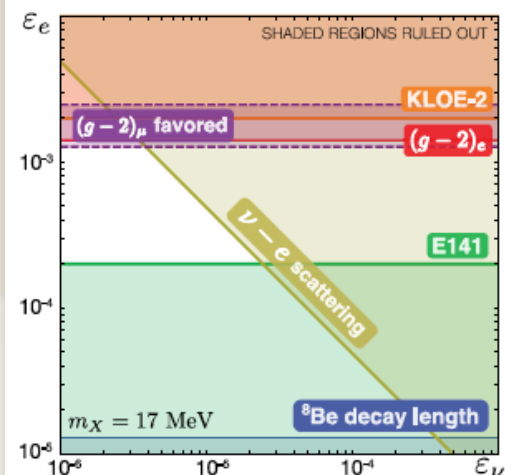
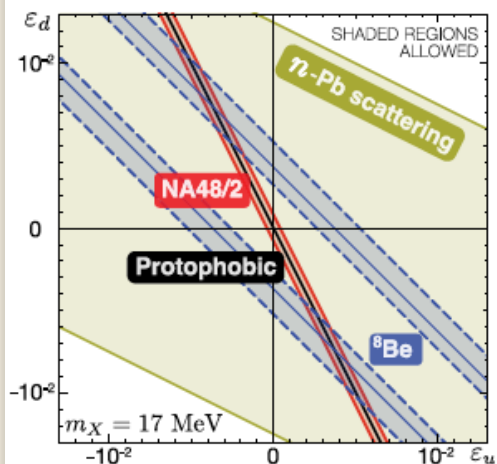

^8Be anomaly at PADME

PHYSICAL REVIEW D **97**, 095004 (2018)

Resonant production of dark photons in positron beam dump experiments

Enrico Nardi,^{1,*} Cristian D.R. Carvajal,² Anish Ghoshal,^{1,3} Davide Meloni,^{3,4} and Mauro Raggi⁵

- Exploit the fact that you “know” where to search 17 MeV
- Exploit the unique possibility to have e^+ at 282.7 MeV @LNF
- Tune E_{e^+} such that $E_{\text{CM}} = \sqrt{2 * m_e * E_B} = 17 \text{ MeV}$
 - Produce A' of 17 MeV on shell through direct annihilation $ee \rightarrow A'$
 - Parametrically enhanced $ee \rightarrow A'$ $O(\alpha)$ wrt $ee \rightarrow A' \gamma$ $O(\alpha^2)$
- Use threshold effect to have solid evidence if any
- Absorb any SM BG in W dump
- Work ongoing on thin target reaches

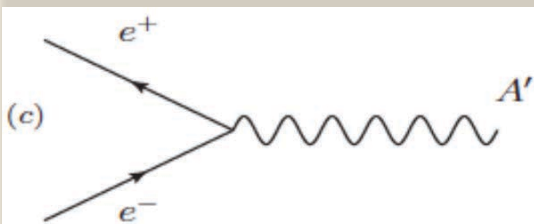
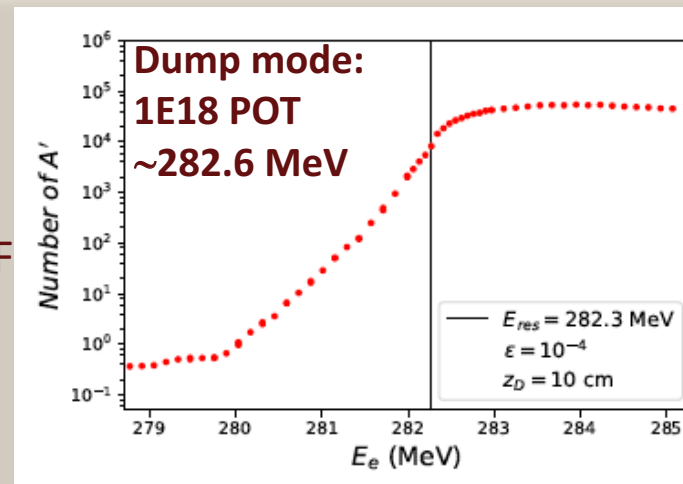

$\epsilon / N_{A'}^{\text{prod}}$	$E_{\text{res}} (v_e = 0)$	E_{res}	$E_{\text{res}} + 2\sigma_b$
1.0×10^{-3}	7.69×10^{11}	1.51×10^{11}	4.72×10^{11}
5.0×10^{-4}	1.81×10^{11}	3.79×10^{10}	1.17×10^{11}
1.0×10^{-4}	7.25×10^9	1.49×10^9	4.73×10^9

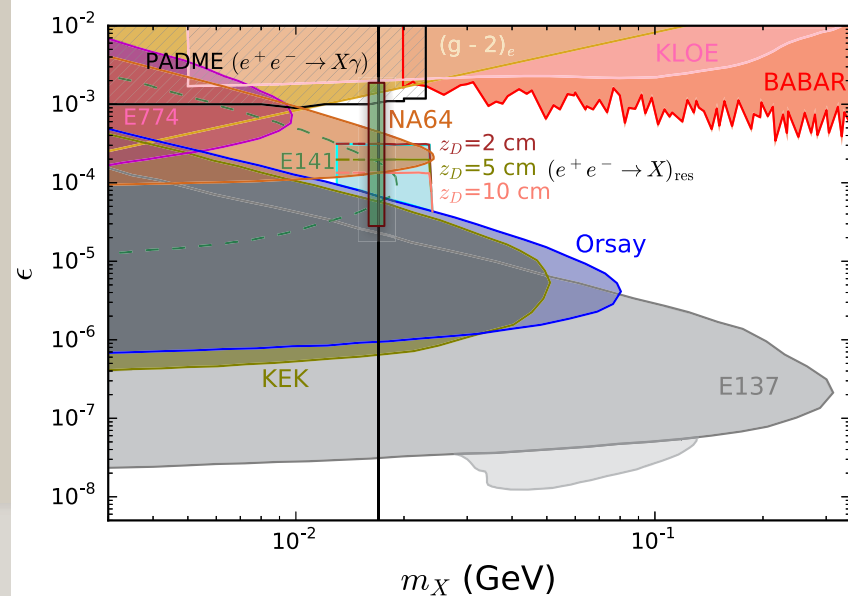

Possible future for PADME in the USA?

Invisibly Decaying Dark Photon

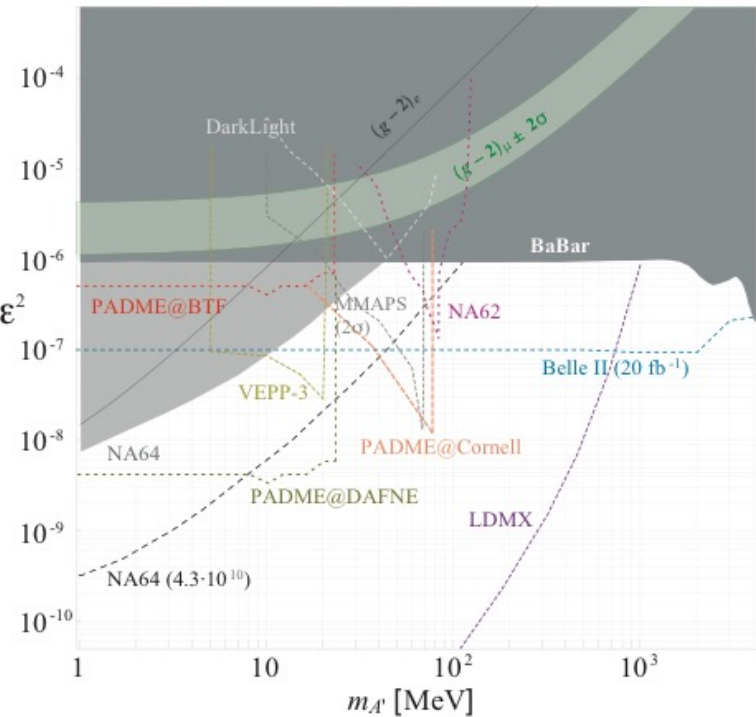

- Main limitation on PADME sensitivity comes from the very small duty cycle of DAFNE Linac ($2E-6 - 1E-5$)
 - 50Hz x (40-250) ns/bunches
- Beam energy limits PADME mass reach
 - 550MeV limits $M_{A'} < 23.7\text{MeV}$
- **PADME moved to CESR @ Cornell can profit of:**
 - x10000 higher luminosity
 - x12 Higher energy (6 GeV) $M_{A'} < 78\text{MeV}$
- **PADME can offer to Cornell:**
 - High spatial and energy resolution BGO crystal Ecal
 - Faster crystals wrt to CLEO CSI(TL)
 - Spectrometer magnet and veto detectors

- Moving PADME to Cornell will be a 1-2M\$ scale project (detector ready by summer of 2018!)
- MRI for the extraction of a positron beam from CESR submitted (Feb 2018)
 - Expecting final decision by October 2018.
- PADME might be able to run @CESR in just few years end of 2021-2022?
- A very interesting physics potential: including visible and invisible A' , ALPs

Conclusions

- The PADME experiment construction is expected to be completed by the beginning of July
- PADME can be the first experiment to explore the process $e^+e^- \rightarrow \gamma A'$, $A \rightarrow \chi\chi$ in a low energy fixed target environment.
- With 1-2 year of running PADME can still extend the BaBar sensitivity to invisible A' decays to lower couplings.
- PADME experiment is **extending its physics case to other dark sector models**
 - Visible Dark Photons, ALPs searches, Fifth force, dark Higgs
- **Starting data-taking by first half July 2018**
- **PADME is aiming at extending its international collaboration**
 - You are welcome to join us!



Join the dark side!

A' to invisible backgrounds

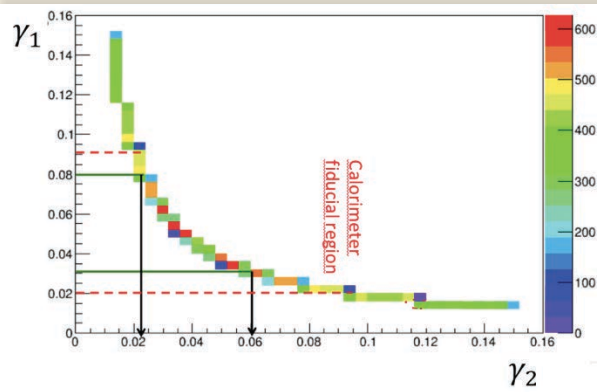

For $\gamma\gamma$ events, given one photon in fiducial region, also the second is in the **calorimeter easy to control**

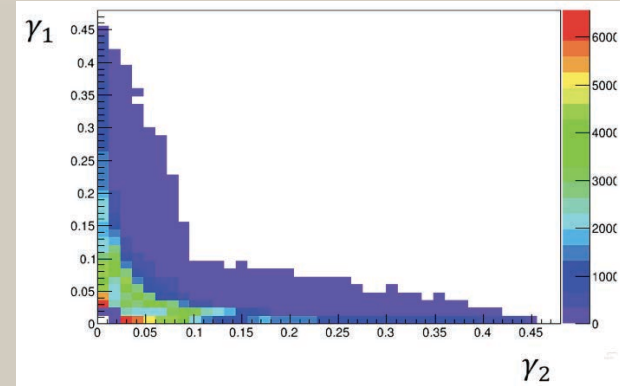

For $\gamma\gamma(\gamma)$ events, given one photon in fiducial region, the **small angle calorimeter** is crucial to recover full efficiency on second photon

Residual background dominated by Bremsstrahlung with e^+ missed by the scintillating bars veto

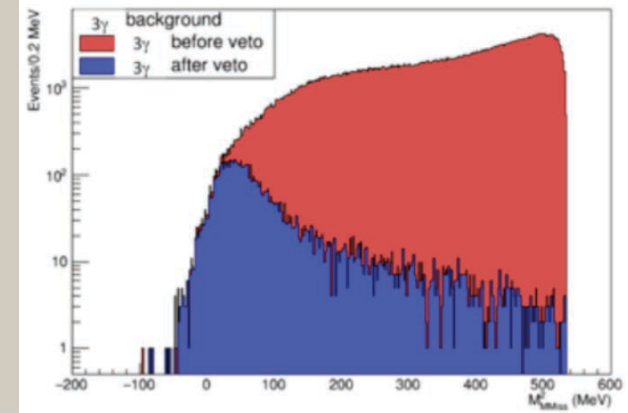
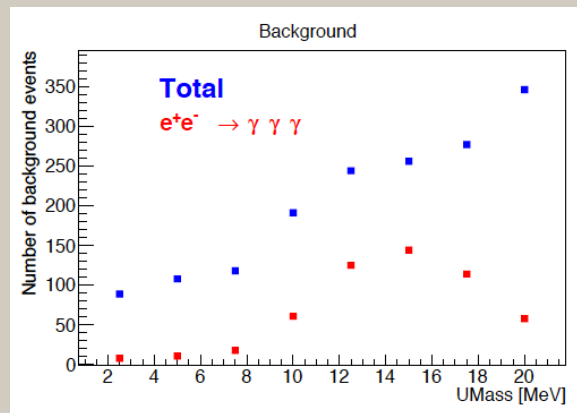
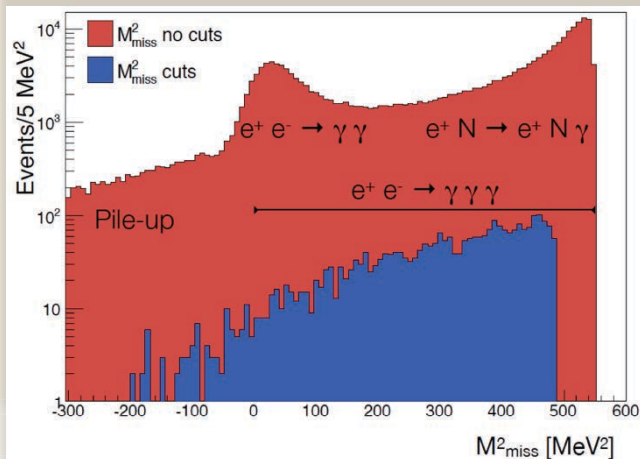

Excitation energy checks

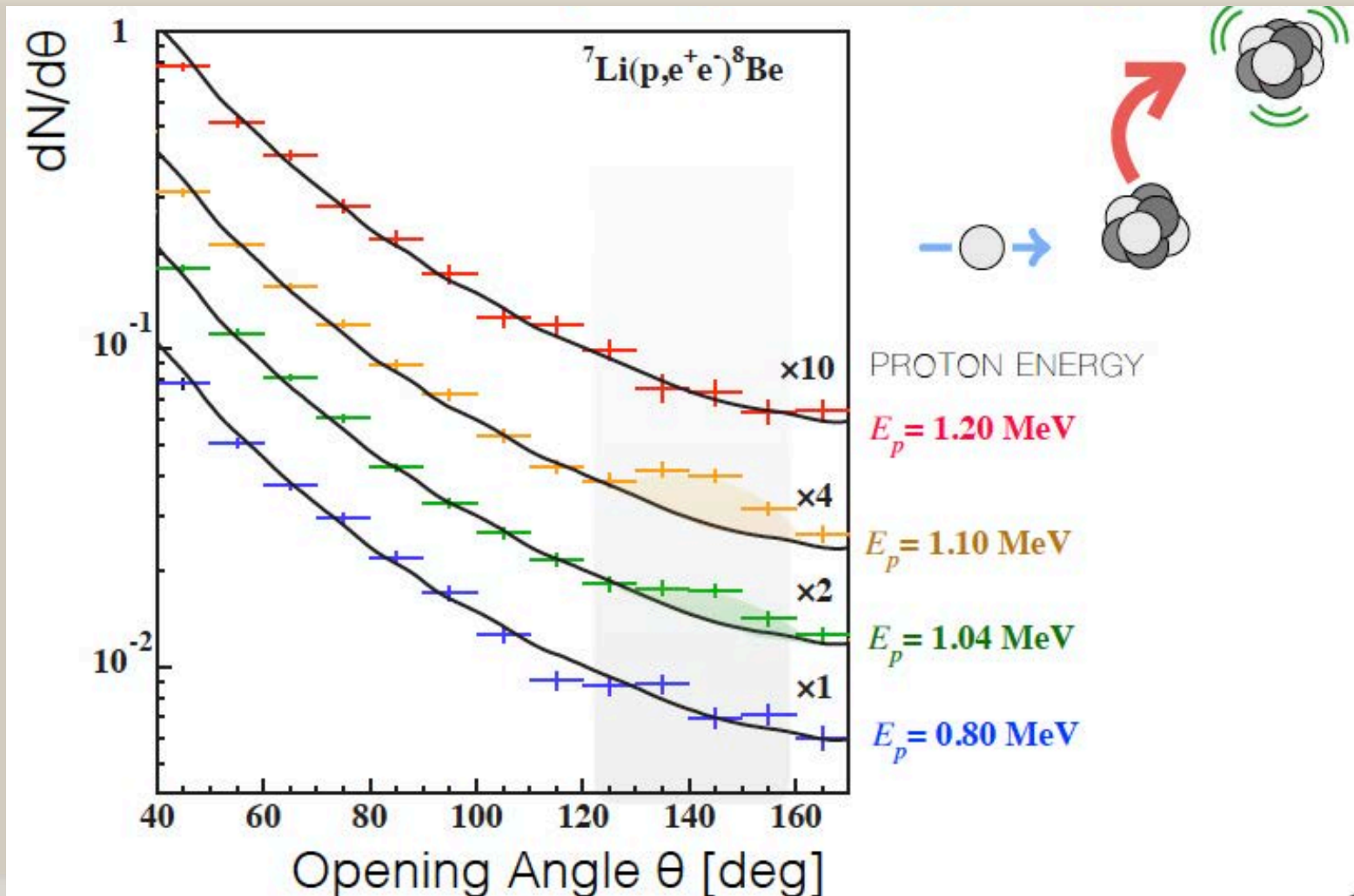

The PADME collaboration

Istituto Nazionale di Fisica Nucleare ITALY

- Hosting the experiment at Laboratori Nazionali di Frascati
- Participating institutions: LNF, Roma1, Roma3, and Lecce
- 32 researchers working on the project part of their time

University of Sofia, prof. Venelin Kozhuharov and collaborators

- Responsibility of scintillator veto detectors
- Grant obtained to participate into PADME in the next 3 years!

MTA Atomki, Debrecen (Hungary), prof. Attila Krasznahorkay and collaborators

Cornell University, CLASSE laboratory, prof. J. Alexander and collaborators

- MRI submitted for positron extraction line at Cornell to run PADME.

College William and Mary, Prof. B. Wojtsekhowski

The University of Iowa, Adj. Prof. Burak Bilki



Istituto Nazionale di Fisica Nucleare



Cornell Laboratory for Accelerator-based Sciences and Education (CLASSE)



The PADME approach to A' searches

The goal

- Develop a dark sector search which is as much as possible **model independent**
 - Explore several models at the same time (Vectors, pseudo-scalars)
- **Minimize the number** of interactions and **parameters** in the data interpretation
 - Need only to describe production mechanism
 - Needs only coupling to electrons
- Provide a **strong and unquestionable experimental evidence for A'**
 - Measure mass and coupling simultaneously can use data driven background estimate!

The way

- Search for the process $e^+e^- \rightarrow \gamma A'$ $A' \rightarrow \text{Inv.}$ by **measuring the final state missing mass**
 - Independent from the A' decay mechanism, A' lifetime, nature and mass of the dark matter χ
- **Measure ε^2** from rate **and $M_{A'}$** from the missing mass
 - Completely constrain the minimal A' model
- Measure ε^2 with minimal theoretical uncertainties
 - Just the delta cross section enhancement factor.

^8Be anomaly at PADME?

2018 experiments

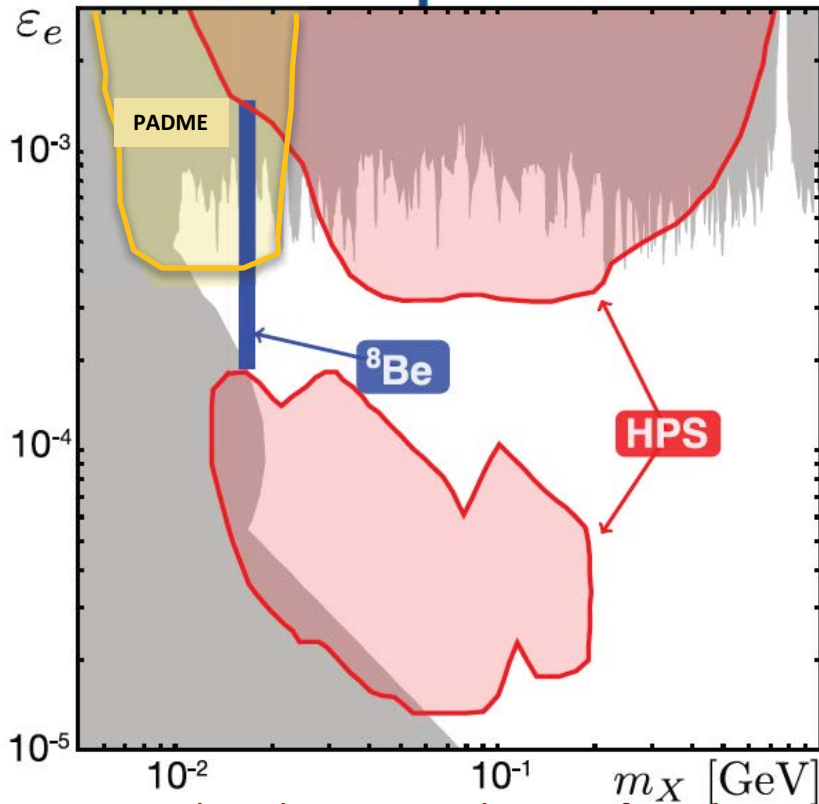

Future experiments

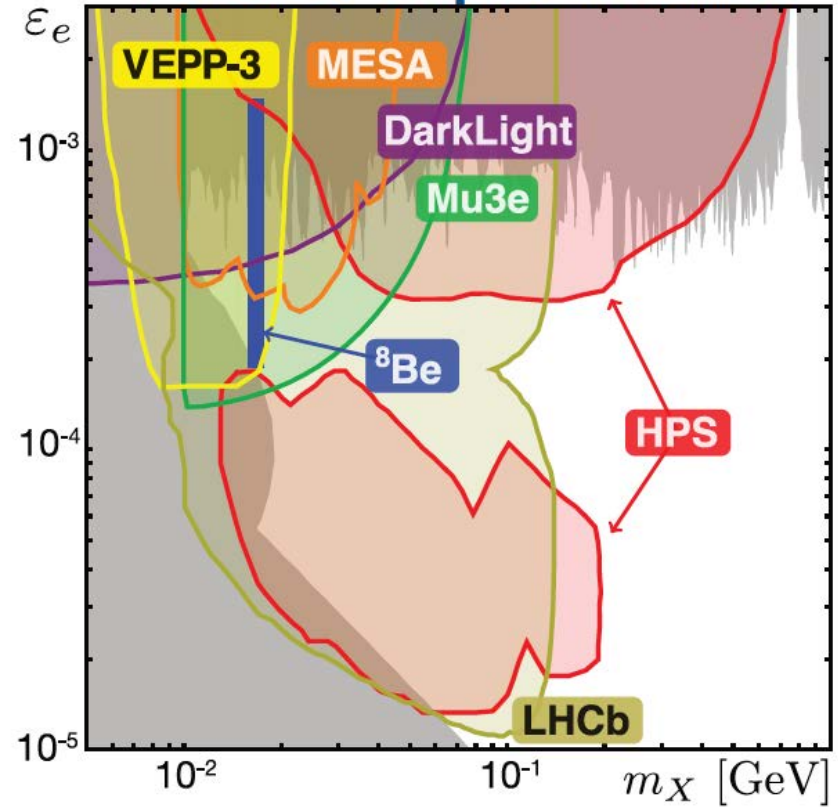

- PADME has the unique chance of producing X in resonant mode BTF a 282 MeV
- Measurement limited from the radiative bhabha scattering $ee \rightarrow eey$
 - Thin or thick target? Get rid of radiative bhabha!
- Need a computation of X production cross section at 550 MeV to assess PADME sensitivity

Residual background

Bremsstrahlung

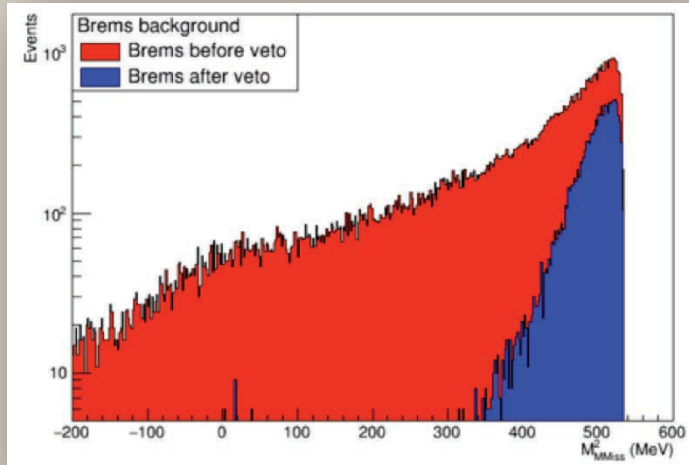

Difficult to veto positron with $E_{e^+} \approx E_{\text{beam}}$ events

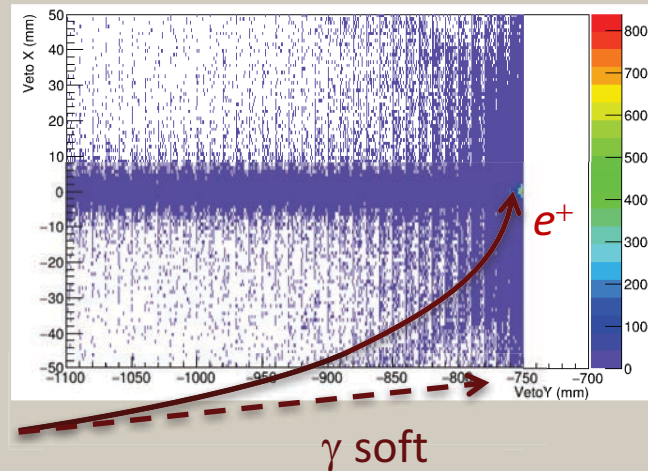

3 photons decay

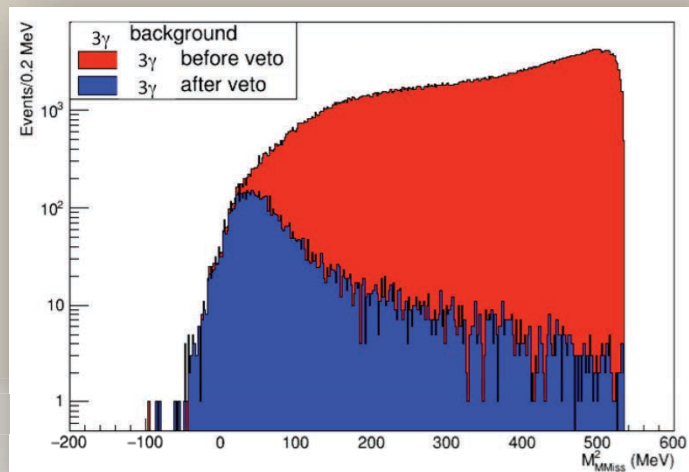

Difficult to veto low energy photons due to high bremsstrahlung rate in the SAC

Design optimization ongoing to reduce residual background new sensitivity expected by summer

Cross sections at PADME

☆ Vladimir Ivantchenko

📁 PADME 24 febbraio 2017 18:38



RE: cross section measurement at PADME

[Dettagli](#)

A: Mauro Raggi, Cc: Paolo Valente e altri 1

Dear Mauro,

For these energies, in Geant4 EM usually theoretical formulas are used for majority of models. Comparison with the data allow to clarify validity of chosen models and their configurations. For EM physics, there are not much data which can be used for validation purposes. For example, known data for bremsstrahlung thin target are available for 1-2 MeV, 15-30 MeV, and 8, 25, 170, 250, 300 GeV. Of course, there are checks in each experiment for calorimeters as a whole, where EM shower is measured and all processes contribute together.

I do not know good thin target data suitable for comparisons for 100-1000 MeV energy range for bremsstrahlung. From my point of view, your measurements may be very useful.

Cheers,
Vladimir

GEANT4 low energy EM libraries

PADME A' main backgrounds

Signal $e^+e^- \rightarrow \gamma A'$

$$M_{\text{miss}} = M_{A'}$$

$p_{\gamma, t}^4$

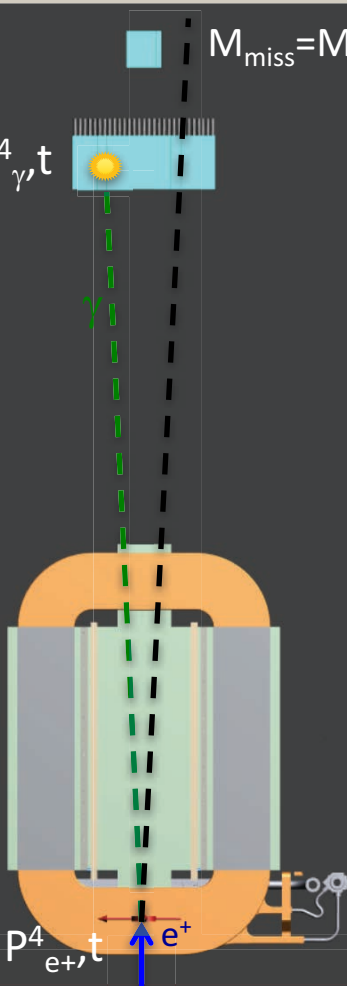

BG annihilation $e^+e^- \rightarrow \gamma\gamma(\gamma)$

1 γ Lost

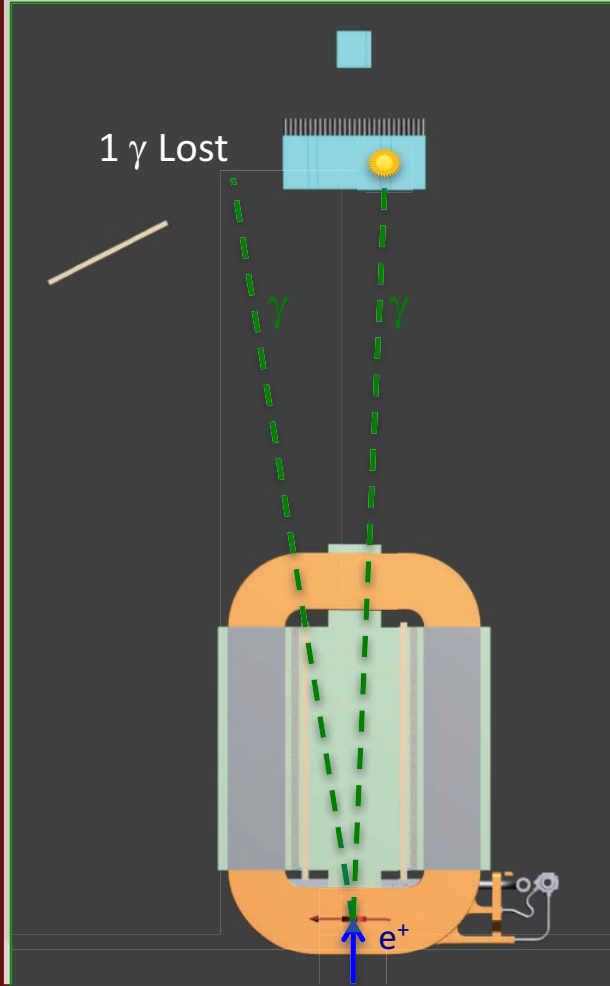

BG SM Brems.: $e^+N \rightarrow e^+N\gamma$

1 e^+ lost

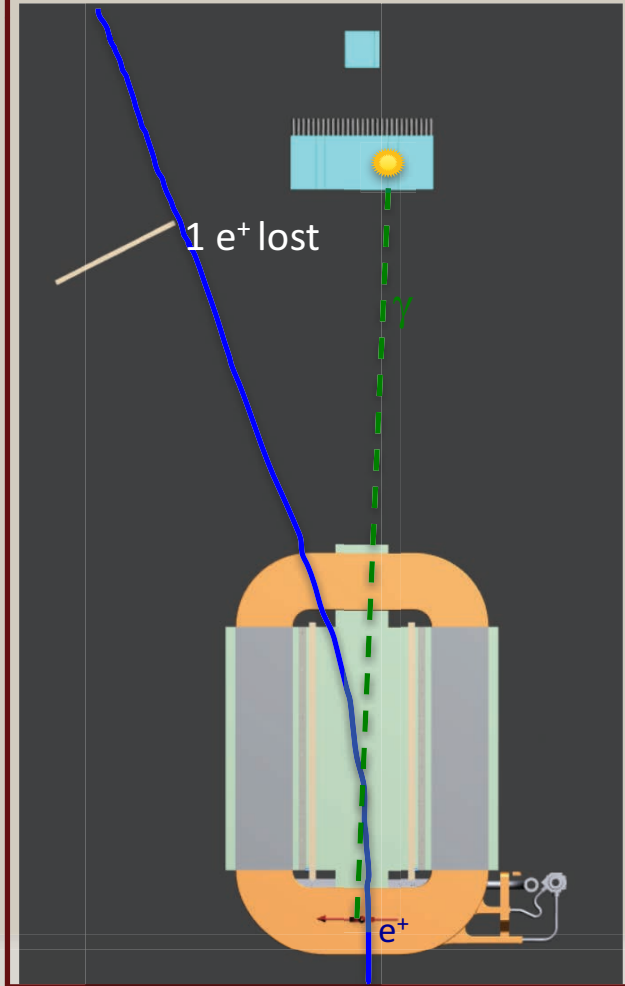

Why at low energy fixed target?

- Can play with the target material to get cross section enhancement (ie high Z)
- Can play with beam energy to get resonant production (if mass is known X Boson)
- Just few background sources
 - (below pion production thresholds only QED is involved)
- Can use electron and positron to isolate exotic annihilation productions.
- Small scale and relatively cheap detectors
- Moreover NO ONE ever performed an A' annihilation search experiment at fixed target!

BTF long pulses

Electron gun

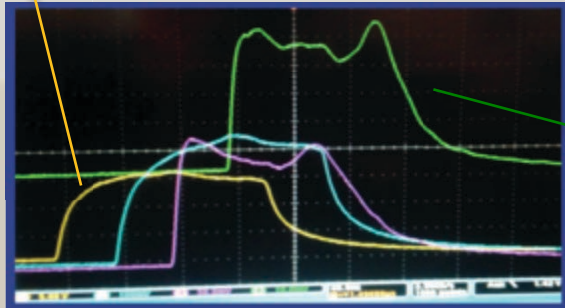

Nov. 8th: Gun at 150 ns, flat pulse,
>510 MeV, 1% spread

End of LINAC

- Ancora è necessario del lavoro di ottimizzazione del LINAC allo scopo di ottenere il miglior possibile **spread** in energia e – di conseguenza – un impulso più piatto su un intervallo temporale più lungo possibile

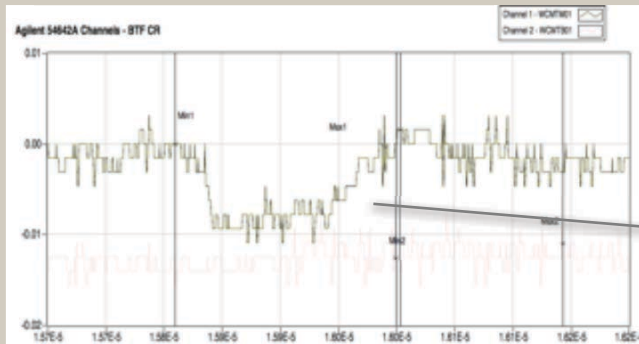

WCM at BTF target

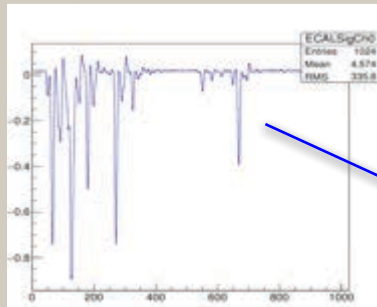

SF57 crystal signal

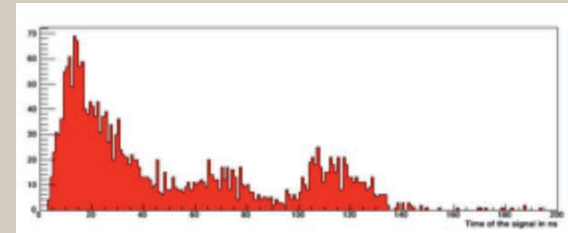

SF57 crystal signals time distribution

Charged particle veto detectors

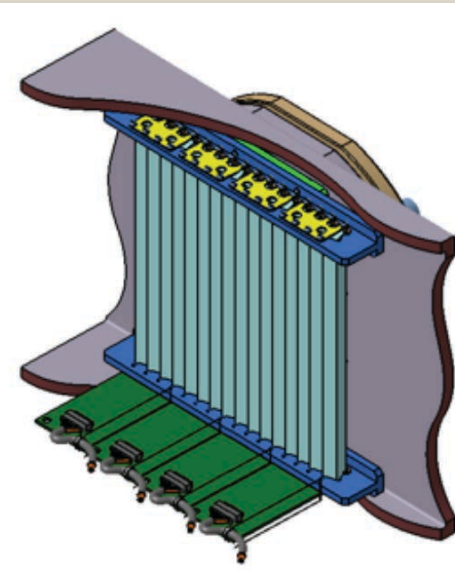
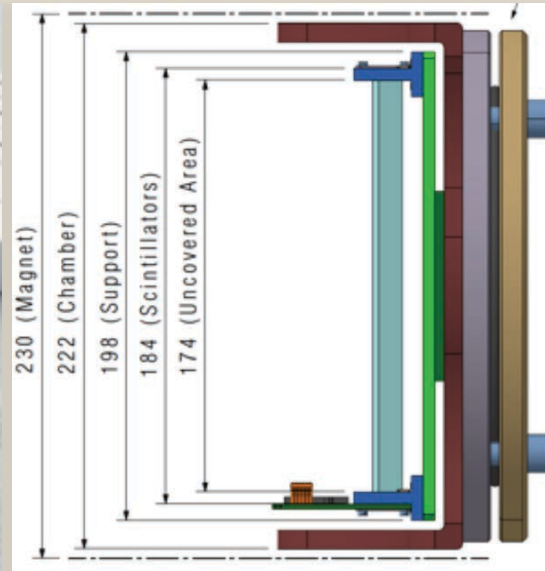
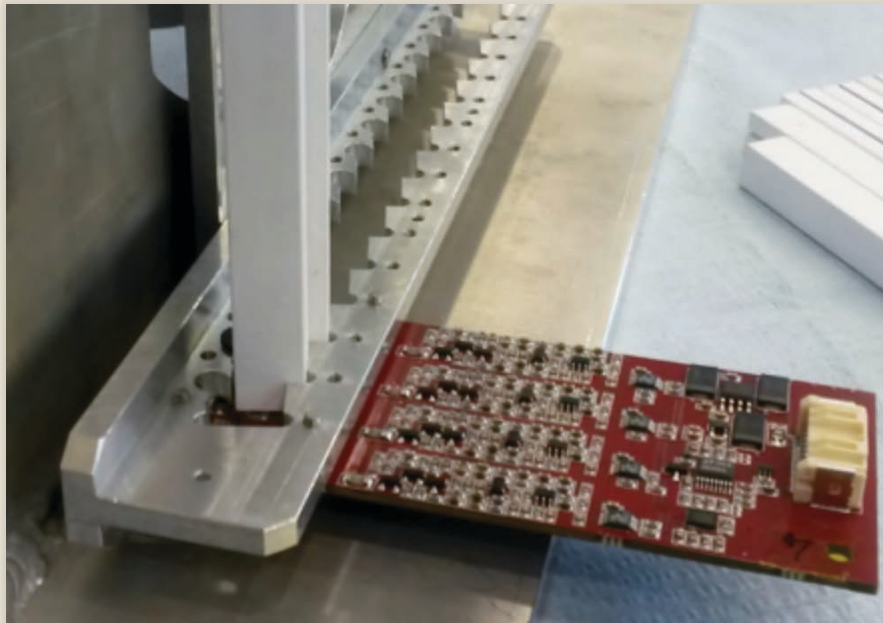

10×10×184 mm³ scintillator read out by silicon Photomultipliers

- All scintillator bars **delivered**
- Design of the mechanics **ready**
 - Prototype of the mechanical assembly **ready**
- Prototype electronics prototype **ready**
 - Test-beam in April to measure efficiency and time resolution
- Read-out by same digitizing system as calorimeter (**ready**)

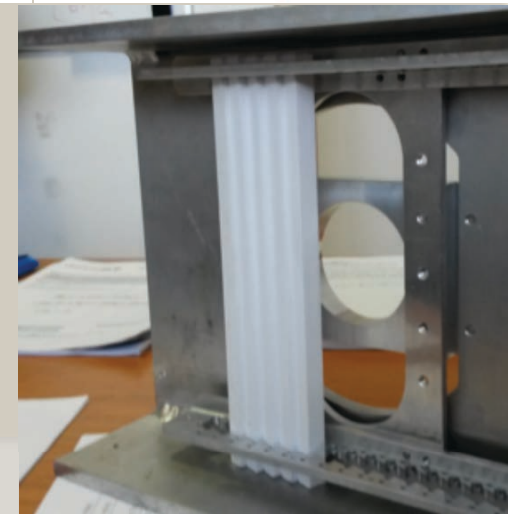

Dark sector search priorhedron[©]

Dark sector coupling prior

		Weak	Strong
$m\chi$ prior	Light	A' invisible decays ALPs	Axions
	Heavy	B-L couplings Proto-phobic ($X \rightarrow ee$)	WIMPs Visible universal A' decays ($ee, \mu\mu, \pi\pi \dots$)

- Early A' searches inspired by strong priors:
 - Heavy dark matter A' the lightest dark sector state
 - A' coupling to fermions universal!
- It's now time to take a step back in the priors and explore a wider panorama
 - Any dark matter mass no prejudice on the coupling to fermions

©Neal Weiner thanks for the inspiring talk